



ENVIRONMENTAL AND SOCIAL MANAGEMENT PLAN FOR HA NKAU SOLAR MINI GRID

Prepared for:

Department of Energy - Lesotho Renewable Energy and Energy Access Project

World Bank, July 2024

For comments or inquiries please contact

Mr Lepekola Lepekola

Environmental and Social Specialist

Lesotho Renewable Energy and Energy Access Project (LREEAP)

Email: llepekola@gmail.com

Mobile: +266 5839 2408

OR,

Mrs Lipalesa Malebese

Environmental Specialist for Preparation of Environmental and Social Management Plan for Development of Ten (10) Solar Mini-grids under LREEAP Component 2B

Email: lipalesamalebese@greenway.co.ls

Mobile: +266 5968 6066

TABLE OF CONTENTS

TABLE OF CONTENTS	III
LIST OF FIGURES	VII
LIST OF TABLES	VIII
ABBREVIATIONS AND ACRONYMS	X
EXECUTIVE SUMMARY	XIII
1 INTRODUCTION	1
1.1 PROJECT BACKGROUND	1
1.2 DESCRIPTION OF THE PROJECT	4
1.3 LOCATION OF THE PROJECT	9
1.4 OBJECTIVES OF THE ESMP	11
2 POLICY AND LEGAL FRAMEWORK	13
2.1 NATIONAL POLICIES AND LEGISLATION	13
2.1.1 <i>Constitution of Lesotho, 1993</i>	13
2.1.2 <i>Environment Act 2008</i>	14
2.1.3 <i>Public Health Order NO.12 OF 1970</i>	15
2.1.4 <i>Occupational Safety and Health Act, Act nO.4 OF 2024</i>	15
2.1.5 <i>Labour Act, ACT NO.3 OF 2024</i>	16
2.1.6 <i>Road Traffic Act No. 8 of 1981</i>	17
2.1.7 <i>Road Transport Act No. 6 of 1981: Part III; Permit</i>	17
2.1.8 <i>Local Government Act 1997</i>	17
2.1.9 <i>National Heritage RESources Act of 2011</i>	18
2.1.10 <i>Land Act (2010)</i>	18
2.1.11 <i>Legal Capacity of Married Persons Act (2006)</i>	19
2.1.12 <i>National Forestry Policy of 2008</i>	19
2.1.13 <i>Gender and Development Policy (2003)</i>	20
2.1.14 <i>Energy Policy (2015-2025)</i>	20
2.1.15 <i>Workmen’s Compensations Act of 1977</i>	21
2.1.16 <i>Decentralization Policy (2014)</i>	21
2.1.17 <i>National Strategic Development Plan 2012/13 – 2016/17</i>	22
2.1.18 <i>Mini Grid Power Generation, Distribution and Supply Regulation of 2021</i>	22
2.1.19 <i>Guidelines for EIA in Lesotho, 2010</i>	23
2.1.20 <i>Customary Law of 1938 (Melao ea Lerotholi)</i>	23

2.2	RELEVANT INTERNATIONAL CONVENTIONS AND STANDARDS TO WHICH LESOTHO IS SIGNATORY	24
2.2.1	<i>World Bank Safeguards Policies and Applicability</i>	24
2.2.2	<i>The World Bank Group Guidelines and Labour Influx</i>	27
2.2.3	<i>Stockholm Convention on Persistent Organic Pollutants</i>	27
2.2.4	<i>Montreal Protocol</i>	28
2.2.5	<i>SADC Declaration on Gender and Development</i>	28
2.2.6	<i>ILO Conventions to which Lesotho is Signatory</i>	28
2.2.7	<i>Convention on the Elimination of All Forms of Discrimination against Women (CEDAW)</i>	29
3	BASELINE ENVIRONMENTAL AND SOCIAL CONDITONS	30
3.1	CLIMATE	30
3.2	AIR QUALITY	31
3.3	FLORA AND FAUNA	32
3.3.1	<i>Flora of Ha Nkau</i>	32
3.3.2	<i>Fauna</i>	34
3.3.3	<i>INTERNATIONAL UNION FOR CONSERVATION OF NATURE (IUCN) status of SPECIES identified at Ha Nkau</i>	35
3.4	WATER RESOURCES	36
3.5	GEOLOGY, GEOMORPHOLOGY AND SOIL TYPE	37
3.6	CURRENT LAND USE	37
3.7	INFRASTRUCTURE AND SOCIOECONOMIC CONDITIONS	38
3.8	ENERGY SITUATION	39
4	POTENTIAL ENVIRONMENTAL AND SOCIAL RISKS AND IMPACTS AND MITIGATION MEASURES	42
4.1	IMPACT ASSESSMENT METHODOLOGY	42
4.2	DESCRIPTION OF POTENTIAL PROJECT IMPACTS AND PROPOSED ENHANCEMENT/MITIGATIONS MEASURES	42
4.2.1	<i>Environmental (BIOphysical) risks and impacts</i>	45
4.2.2	<i>Social and Economic risks and impacts</i>	54
4.2.3	<i>Health and Safety risk and impacts</i>	62
4.3	PROPOSED MITIGATION MEASURES	65
4.3.1	<i>Environmental Mitigation Measures</i>	65
4.3.2	<i>Socio-ecomic Mitigation Measures</i>	73
4.3.3	<i>Health and Safety Mitigation Measures</i>	79

5	ESMP MONITORING AND REPORTING	85
5.1	MONITORING AND REPORTING OBJECTIVES	85
5.2	MONITORING AND EVALUATION INDICATORS	85
5.3	ENVIRONMENTAL AND SOCIAL MANAGEMENT COMPLIANCE MONITORING	86
5.4	ESMP REPORTING	99
5.4.1	<i>Reporting by PIU</i>	<i>99</i>
5.4.2	<i>Environment, Health and Safety Incidents</i>	<i>99</i>
5.4.3	<i>Record Keeping</i>	<i>100</i>
5.4.4	<i>Adaptive Management</i>	<i>100</i>
6	INSTITUTIONAL ARRANGEMENTS FOR ENVIRONMENTAL AND SOCIAL MANAGEMENT PLAN	101
6.1	ROLES AND RESPONSIBILITIES	102
6.2	INSTITUTIONAL ARRANGEMENTS	106
7	TRAINING AND AWARENESS RAISING	109
7.1	CAPACITY DEVELOPMENT FOR PROJECT WORKERS	109
7.2	ENVIRONMENTAL, SOCIAL, HEALTH AND SAFETY INDUCTION	110
7.3	CONTRACTOR’S INTERNAL TRAININGS	111
7.3.1	<i>Toolbox Talks</i>	<i>112</i>
8	STAKEHOLDER CONSULTATIONS	114
8.1	OVERVIEW	114
8.2	STAKEHOLDER CONSULTATIONS	114
8.2.1	<i>Key Informants’ Interviews</i>	<i>115</i>
8.2.2	<i>Institutional Consultations</i>	<i>117</i>
8.2.3	<i>Consultations with local authorities</i>	<i>119</i>
8.3	INFORMATION DISCLOSURE	120
8.4	GRIEVANCE REDRESS MECHANISM (GRM)	121
8.4.1	<i>GRIEVANCE REDRESS COMMITTEE</i>	<i>122</i>
8.4.2	<i>ACCESSIBILITY OF THE GRM</i>	<i>123</i>
8.4.3	<i>GRIEVANCE REDRESS PROCESS</i>	<i>123</i>
8.4.4	<i>Managing GBV/SEA/SH related grievances</i>	<i>124</i>

8.5	MEASURES TO ENSURE CONTINUED STAKEHOLDER ENGAGEMENT THROUGH-OUT THE PROJECT LIFE CYCLE	124
9	IMPLEMENTATION SCHEDULE AND COST ESTIMATES	127
10	INTEGRATION OF THE ESMP WITH PROJECT	129
11	ANNEXURES	130
11.1	REFERENCES	130
11.2	LIST OF ASSOCIATED REPORTS AND PLANS	133
11.3	IMPACT ASSESSMENT METHODOLOGY	133
11.4	CODE OF CONDUCT	136
11.5	MONITORING CHECKLIST	139
11.6	CHANCE FIND PROCEDURE	152
11.7	PUBLIC PARTICIPATION & CONSULTATIONS REPORT	155
11.7.1	<i>Key Informant Interviews (KII)</i>	<i>155</i>
11.7.2	<i>Institutional consultations and interviews with area chiefs</i>	<i>162</i>
11.7.3	<i>Community awareness (COnducted by LREEAP) report for Ha Nkau (2023)</i>	<i>163</i>

LIST OF FIGURES

Figure 1- 1: Components of a solar mini-grid5

Figure 1- 2: Illustration of the components of solar mini-grids 6

Figure 1- 3: Solar PV array 7

Figure 1- 4: A fixed tilt tracking system versus a solar-axis tracking system (Kristine, 2023)8

Figure 1- 5: Ha Nkau concession areas 10

Figure 1- 6: The specific objectives of the ESMP 12

Figure 3- 1: *Gazania krebsiana (tsikitlane)* at Seforong 33

Figure 3- 2: *S. runcinata (mosisili)* observed at Ha Nkau33

Figure 3- 3: *Euphorbia clavarioides (sehlooko)* 34

Figure 3- 4: Senqu River cutting through Ha Nkau project villages 36

Figure 3- 5: Yellowish hard sandstone rock37

Figure 3- 6: Green vegetables subsistence farming at Ha Nkau 38

Figure 3- 7 Solar panels for pumping water out of the borehole at Ha Nkau39

Figure 3- 8 Hareeng Combined School at Ha Nkau 39

Figure 3- 9 : Ha Nkau percentage usage of energy sources 41

Figure 6- 1: Organogram illustrating the key role players in the project**Error! Bookmark not defined.**

Figure 8- 1: Energy related challenges experienced in Ha Nkau 118

LIST OF TABLES

Table 1- 1: List of mini-grid sites	1
Table 2- 1: OPs and BPs applicable to Ha Nkau solar mini-grid	25
Table 2- 2: Fundamental ILO conventions to which Lesotho is signatory	28
Table 3- 1: Climate conditions for Quthing- Monthly Averages	30
Table 3- 2: Climate conditions for Mohale's Hoek - Monthly Averages	31
Table 3- 3: Land cover and vegetation at Ha Nkau	32
Table 3- 4: IUCN status of species found at Ha Nkau	35
Table 3- 5: Socioeconomic and infrastructure conditions in Ha Nkau	38
Table 4- 1: Description of potential environmental risks and impacts for different phases of the project	45
Table 4- 2: Description of potential social risks and impacts for different phases of the project	54
Table 4- 3: Description of potential health and safety risks and impacts for different phases of the project	62
Table 4- 4: Environmental Mitigation Measures	65
Table 4- 5: Socio-economic Mitigation Measures	73
Table 4- 6: Health and Safety Mitigation Measures	79
Table 5- 1: Environmental, social, health and safety management monitoring indicators	85
Table 5- 2 : Environmental Management and Monitoring Plan of identified potential impacts	88
Table 6- 1: Implementing Agency and Financier	106
Table 6- 2: Contractor/Developer	107
Table 6- 3: Other Government Departments responsible in implementation of the ESMP	108
Table 7- 1: Capacity needs for other role players	109
Table 7- 2: Environmental safeguards induction trainings	111
Table 8- 1 Sample Grievance form – Ha Nkau solar mini-grid	122
Table 9- 1: Overall cost estimation for the Ha Nkau mini-grid	128

Table 11- 1: Key informant interviews 155

Table 11- 2: The institutions and respondents consulted in Ha Nkau in the development of this report 163

ABBREVIATIONS AND ACRONYMS

AC	Alternating Current	EIA	Environmental Impact Assessment
AIDS	Acquired Immune Deficiency Syndrome	EMC	Environmental Management Committee
AP(s)	Affected Parties	ERC	Energy Research Centre
ARAP	Abbreviated Resettlement Action Plan	ESMF	Environmental and Social Management Framework
CEDAW	Convention on the Elimination of All Forms of Discrimination against Women	ESMP	Environmental and Social Management Plan
CEHSMP	Contractor's (Construction) Environmental Health and Social Management Plan	ESS	Environmental and Social Specialist
CERC	Contingent Emergency Response Component	e-waste	Electronic waste
CLO	Community Liaison Officer	GBV	Gender Based Violence
CoC	Code of Conduct	GC	Grievance Committee
COVID-19	Coronavirus Disease 2019	GDP	Gross Domestic Product
DC	Direct Current	GM	Grievance Mechanism
DoE	Department of Energy	GoL	Government of Lesotho
DoEnv	Department of Environment	GRM	Grievance Redress Mechanism
EHS	Environmental Health and Safety	HIV	Human Immunodeficiency Virus
EHSGs	Environmental, Health and Safety Guidelines	HOMMER	Hybrid Optimization of Multiple Energy Resources

IDA	International Development Association	PAD	Project Appraisal Document
ILO	International Labour Organization	PESIA	Preliminary Environmental and Social Impact Assessment
IP	Interested Parties	PIM	Project implementation Manual
LAA	Land Administration Authority	PIU	Project Implementation Unit
LEC	Lesotho Electricity Company	PM	Particulate Matter
LHWP	Lesotho Highlands Water Project	PPE/C	Personal Protective Equipment/ Clothing
LPG	Liquefied Petroleum Gas	PPP	Public Private Partnership
LREEAP	Lesotho Renewable Energy and Energy Access Project	PV	Photovoltaic
LV	Low Voltage	RF	Resettlement Framework
MGYSR	Ministry of Gender, Sports and Recreation	SACU	South Africa Customs Union
MISPs	Management Implementation Strategy Plans	SDG	Sustainable Development Goal
MoE	Ministry of Energy	SEA	Sexual Exploitation and Abuse
MOSCET	Mos-Sun Clean Energy Technologies	SH	Sexual Harassment
MV	Medium Voltage	SHE	Safety Health and Environment
MW	Mega Watt	SREP	Scaling up Renewable Energy Program
NUL	National University of Lesotho	STIs	Sexually Transmitted Infections
NSDP	National Strategic Development Plan	TORs	Terms of Reference

OHS	Occupational Health and Safety	WB	World Bank
OP	Operational Policy	WHO	World Health Organization

EXECUTIVE SUMMARY

INTRODUCTION

Access to electricity is low in the Kingdom of Lesotho although the country has potential to achieve universal access by 2030 using clean, renewable energy resources. Nationwide, about 50.38% of households have access to electricity, comprising 60% for urban and peri-urban households and 18% for rural households. Almost all those with access to electricity are grid connected. A larger part of the country is largely mountainous with low population densities making access to the grid very difficult.

Rural households (which are mostly in mountainous areas) rely on paraffin and candles as sources of energy for lighting, heating and cooking; and majority of households use wood and dung for cooking. Burning these fuels in the home can lead to negative health impacts. Gathering these fuels can also be time-consuming for households. According to African Clean Energy's 2015 survey of 2,652 rural households in Lesotho, households – mostly women and children - spent 31 hours per month travelling for fuel. A number of these rural communities are involved in subsistence farming with no value addition due to lack of modern technologies which could be run by electricity. Basic social services like health and education are also disadvantaged due to lack of electricity.

The Government of Lesotho (GoL) through the Ministry of Energy is implementing the project titled: "Lesotho Renewable Energy and Energy Access Project (LREEAP)". The objective of the project is to increase access to electricity in rural and peri-urban areas of Lesotho. The project will support the vision of Kingdom of Lesotho Energy Policy 2015-2025 which states that "Energy shall be universally accessible and affordable in a sustainable manner, with minimal negative impacts on the environment", through: grid extension to industrial zones; grid extension to households; as well as deployment of mini-grids using Public-Private Partnership (PPP) models. The project seeks to provide electricity access to schools, health centres, households, micro, small and medium enterprises in off grid communities across the country through renewable energy sources. In this regard, LREEAP proposes to develop 10 solar mini-grids under Component 2B with Ha Nkai being one of the selected mini-grid locations.

The national laws, policies and guidelines relevant to the Project include the Constitution of Lesotho of 1993, Environment Act No. 10 of 2008, Public Health Order No.12 of 1970, Lesotho

Labour Code No.24 of 1992, and Road Traffic Act No.8 of 1981 as well as the Local Government Act No. 6 of 1997. The other legislations are National Heritage Resource Act of No. 8 of 2012, Land Act No.8 of 2010, and Legal Capacity of Married Persons Act No.9 of 2006. The policies relevant to the Project are Gender and Development Policy and the Energy Policy. The Project has the potential of triggering the following World Bank Safeguard policies: OP 4.01 - Environmental Assessment, OP 4.04 - Natural Habitats; OP 4.11 Cultural Physical Resources and OP.4.12 Involuntary Resettlement. The Project is classified as a category B project according to World Bank OP 4.01. In order to ensure good management practices for implementation of the proposed solar mini-grid project for Ha Nkau, a project specific ESMP was developed.

BASELINE DESCRIPTION

Ha Nkau concession areas are located in Mohale's Hoek and Quthing districts. In terms of agro-ecological zones, parts of the area are within the Senqu River Valley while some are located in highlands of Lesotho.

There was variety of vegetation species observed and reported some of which are medicinal or have other uses by locals in the project area. These include *S. runcinata (mosisili)* and *Gazania krebsiana (tsikitlane)* *Euphorbia clavarioides (sehloko)*, pine trees and eucalyptus forests. Domestic animals including sheep, goats, cattle, horses and dogs were observed and there were reports of the existence of wild animals that include black backed jackal, rock rabbit and wild cats.

In terms of socio-economic environment, Ha Nkau concession areas are serviced with a health centre, schools, rural water supply and improved ventilated pit latrines (VIP) in most of the enumeration areas. Water supply was however reported to be great challenge in one of the villages. Majority of the population survives through subsistence farming. For energy sources, most households and schools in the project area rely on burning of biomass as their source of energy for cooking and use paraffin and candles for lighting hence, the project will increase access to a more reliable and clean source of energy. Insitutions such as the health center in project area area equipped with solar panels for energy supply.

POTENTIAL IMPACTS

There are a number of potential impacts presented by the proposed sub-project. These include both positive and negative impacts on different aspects of the natural and socio-economic environment as per the table below.

Potential Impacts on Biophysical Environment	Potential Socio-Economic Impacts	Potential Health and Safety Impacts
<ul style="list-style-type: none"> • Loss of vegetation; • Exacerbated soil erosion; • Land use and visual impact or loss of environmental aesthetics; • Soil and water pollution; • Wastewater and effluent; • Waste management; • Air pollution; • Noise pollution; • Generation and exposure of hazardous waste oils/chemicals; • Natural risks/disasters; • Avian collision and electrocution; • Environmental conservation. 	<ul style="list-style-type: none"> • Loss of livelihoods/ property/ land/ relocation of community utilities; • Employment creation and skills development; • Influx of job seekers; • Trafficking in persons; • Social exclusion: Inability to connect to the mini-grid; • HIV/AIDS, GBV AND SEA/SH; • Impact on Physical Archaeological Impacts; • Conflicts; • Community health and safety: Improved health and safety; • Increased security; • Women empowerment; • Improved accessibility to an affordable source of energy; • Improvement in the standards of living and livelihoods; • Increased demand for local business/ informal traders; • Economic growth. 	<ul style="list-style-type: none"> • Occupational health and safety incidents; • Community health and safety incidents; • Onset of non-communicable disease and spread of communicable diseases; • Increased fire risk; • Public safety.

PROPOSED MITIGATIONS MEASURES

This Environmental and Social Management Plan (ESMP) has been developed following assessment of the potential environmental risks and impacts of the proposed sub-project on the receiving biophysical and social environment. The aim of the instrument is to provide practical and detailed mitigation measures and management actions required for management of identified environmental and social impacts of the proposed project.

Mitigation measures are provided to ensure that potential negative impacts are minimized and positive impacts are enhanced hence the developed ESMP should be implemented for all phases of the project. Some of the proposed mitigation measures for both the construction and operation phases include among others development of clear recruitment procedures together with local authorities, sustainable use of resources, and protection of areas susceptible to erosion, provision of proper ablution facilities for workers on site and implementation of the waste management plan.

Furthermore, it is important to ensure that all necessary measures are taken to reduce environmental and social risks, such that fires are not started as a result of construction or operation phase related activities. The ESMP also describes grievance mechanism, chance find procedure as well as the roles and responsibilities to ensure its implementation and monitoring and reporting requirements. The Contractor will be required to develop Construction Environmental Management Plan or Environmental Protection Plan and Occupational Health and Safety (OHS) Plans containing Management Implementation Strategy Plans (MISPs) including the following:

- Corporate social responsibility plan;
- Labour influx management plan;
- Waste Management plan;
- Erosion control plan;
- Fire prevention plan incorporating vegetation management (particularly for the solar PV plant area and surrounds during the operation phase).

STAKEHOLDER ENGAGEMENT

Stakeholder consultations were carried out with relevant stakeholders including Department of Energy, Lesotho Electricity Company (LEC), National University of Lesotho Energy Research Centre (NUL-ERC) MOSCET, and 1POWER. Consultations were also made with area chiefs and various institutions within the project areas and they included health centres, schools and

commercial centres. The aim was to further engage with and obtain their comments, concerns and recommendations. Their comments were taken into account during the impact assessment and development of mitigation measures.

INSTITUTIONAL FRAMEWORK AND ESMP IMPLEMENTATION AND BUDGET

The Ministry of Energy - LREEAP Project Implementation Unit (PIU) team, will implement the ESMP. They will also, ensure that the relevant provisions are integrated into the Contractor's procurement contract and other pertinent documents, including the signing of the various Codes of Conduct (CoC), and implementation of Grievance Redress Mechanism (GRM) instructions to Contractors. Implementation progress shall be documented and reported periodically to the Government of Lesotho (GoL) and the World Bank (WB) Group and adhering to the applicable legislative provisions.

The projected cost for ESMP implementation is fifty-nine thousand, six hundred and thirty-nine United States Dollars and sixty-five cents (**59,639.65**) using the exchange rate of 18.70 LSL to 1 US\$ which is mainly for the construction phase with anticipated duration of 12 months. The cost estimate for monitoring be included in the project cost as monitoring will be done by LREEAP staff. Training costs shall be carried out by the LREEAP-PIU therefore the total cost estimation shall be covered shall be **US\$ 19,000** covered in the project operational budget.

The overall cost estimation including 10% contingency price for the mini-grid at Ha Nkai is seventy thousand, seven hundred and seventy-five United States Dollars, and sixty-eight cents (**US\$ 70,775.68**).

1 INTRODUCTION

1.1 PROJECT BACKGROUND

The Government of Lesotho (GoL) through the Ministry of Energy is implementing the project titled: “Lesotho Renewable Energy and Energy Access Project (LREEAP)”. The objective of the project is to increase access to electricity in rural and peri-urban areas of Lesotho. The project will support the vision of Kingdom of Lesotho Energy Policy 2015-2025 which states that “Energy shall be universally accessible and affordable in a sustainable manner, with minimal negative impacts on the environment”, through: grid extension to industrial zones; grid extension to households; as well as deployment of mini-grids using Public-Private Partnership (PPP) models. The project seeks to provide electricity access to schools, health centres, households, and micro, small and medium enterprises in off grid communities across the country through renewable energy sources. In this regard, LREEAP proposes to develop 10 solar mini-grids under Component 2B with Ha Nkau being one of the selected mini-grid locations. The list of the mini-grid village locations and the relevant districts is given in table 1-1:

Table 1- 1: List of mini-grid sites

Village	Enumeration Areas (EAs)	District
Liphiring	Ha Mokhele, Letsatseng, Ha Raboko, Matlapaneng, Ha Makhatla, Ha Ramokhethi, Majapereng, Lipeleng, Thabeng, Ha Lekhoee, Lipeleng	Mohale’s Hoek and Quthing
Ha Nkau	Mokopung, Ha Seqhoke, Hloahloeng, Ha Mphutheha, Seforong, Matebeleng, Mpharane, Ha Mosi.	
Bobete	Mahahleng, Makhuleng, Morareng Ha Mampuseng, Setoetsoe, Bobete Ha Khoaisanyane, Ha Maanela, Ha Maanela Sekoting, Ha Lebala	Thaba-Tseka
Methalaneng	Methalaneng, Khutlo-se-metsi, Ha Kokoana, Ha Khopiso	
Lesobeng	Ha Lephoi, Thokoana, Ha Letsika, Ha Mohau, Thaba-Ntsó, Malimong, Khorosaneng, Ha Mahau, Phalole, Tumahole, Choroane, Matsoeteng,	
Semenanyame	Semenanyane, Iketleng, Methalaneng, Maiseng, Ha Seloloana (Khopung), Ha Sekereu (Bochabela), Ha Soai, Ha Tsóeukhala, Ha Matona, Poni, Ha Toebea, Matholeng.	
Molikaliko	Ha Meta, Mahemeng, Ha Rammeleke, Thaba-Limpe, Paballong, Ha Mphuthelane, Mabuleng, Ntsoana-Tsatsi, Molika-Liko, Matebeleng, Limokaneng, Mafurapela, Ha	Mokhotlong

Village	Enumeration Areas (EAs)	District
	Nthibulane, Khonofaneng, Pae-la-Itlhatsoa, Ha Moroka.	
Malefiloane	Moshemong, Ha Hlakane, Thaba-Khubelu, Linotsing, Phutha-Taung, Mohlanapeng, Ha Malapane, Malefiloane, Kholokoe, Letseng, Mateanong, Ha Jerose, Lentsoeteng, Ha Leutsoa, Liqobong, Ha Ralefatla	
Linakaneng	Boiketlo, Ha Matjota, Mankeng, Boinyatso, Nkokamele, Linakaneng, Mohloaing, Thaba-Nts'ò, Cattle Post, Lulang, Ha Mpheelle,	
Qhoalinyane	Ha Nthunya, Ha Tlhaku, Matikareng, Ha Sehloho, Sekhabalateng, Qoalinyane, Ha Ramatséoa, Ha Letsooa, Matsoapong, Ha Shakhane, Ha Malefane, Ha Raene, Ha Seqalaba, Ha Ntoko, Ha Joele, Ha Tlhoró, Maboloka	Mohale's Hoek and Quthing

This Environmental and Social Management Plan (ESMP) is prepared in order to ensure that component 2B is implemented in accordance with relevant World Bank Safeguards Policies and Lesotho legislation, in particular the Environment Act of 2008.

The LREEAP project is comprised of 4 components:

Component 1: Grid extension to Peri-Urban Areas of Lesotho

This component includes financing of design, procurement of materials and construction works required for electrification to be implemented by LEC. It will contribute to construction of Medium Voltage (MV) and Low Voltage (LV) distribution lines (33 kV/11) as well as upgrading of existing or construction of new substations. The model envisioned is particularly viable for LEC, as the electrical corridors built under the project to connect large new customers will also be used by the utility to develop its LV network to underserved residential customers, accelerating the achievement of LEC's and the GoL's electricity access expansion targets

Grid extension to households will involve the following sub-project activities across the country: Construction of substations and low voltage lines; wiring, testing, commissioning and electrification of households and public institutions (schools, health facilities, churches, local government offices, local courts, agricultural resource centers) and businesses.

Component 2: Electrification by Mini-Grids

The component supports the electrification of areas where electricity supply through mini grids represents the least-cost option from a country's perspective. It involves rehabilitation and upgrading of LEC mini-grid at Semonkong. Mini-grid deployment under PPP Models is part of this component which will support electrification of areas where electricity supply through mini-grids represents the least-cost option.

Subcomponent 2A: Rehabilitation and Upgrading of LEC Mini-grid at Semonkong (SREP Loan US\$3.5 million, SREP Grant US\$2 million): This subcomponent will fund the rehabilitation and upgrading of Semonkong, a hydro-based mini-grid with diesel as an alternative electricity supply source. Therefore, rehabilitation of the turbine, expansion of generating capacity by adding 1.5 MW of solar PV and 500 kWh of storage, and the upgrade of the operational mechanisms for the simultaneous production of electricity by multiple supply sources are required and will be funded by the project.

Subcomponent 2B: Mini-grid Development under public-private partnership (PPP) Models (IDA US\$10 million, SREP Loan US\$4.5 million): This subcomponent will support the electrification of areas where electricity supply through mini-grids represents the least-cost option from a country perspective, as underpinned by geospatial analysis. This subcomponent will fund the deployment of several mini-grids using private sector-led business models and help create state-of-the-art projects using mini-grids that will (a) test various PPP business models for service delivery; (b) improve availability of mini-grid market information, thereby attracting private sector participants; (c) offer technical support for due diligence and project implementation; (d) create customer awareness about different tiers of service offered by mini-grids; and (e) provide grid connections to approximately 4,800 customers to link them to the mini-grids supported under the Project; and (f) provide technical assistance to carry out associated feasibility studies and technical-economic analysis and implementation support activities for addressing technical, procurement, legal, environmental, social and capacity-building matters.

Component 3: Technical Assistance and Implementation Support

The component mainly supports project implementation and coordination, women employment, female entrepreneurship, consumer education and citizen engagement as well as productive uses of energy.

Subcomponent 3A: Project Implementation and Coordination Support (SREP Grant US\$2.5 million): This subcomponent will strengthen the capacity of the sector stakeholders for coordination, project management, and implementation. Activities will include (a) the hiring of independent verification agents (IVAs); (b) hiring of monitoring and evaluation staff; (c) management of certification program for companies; (d) establishment of a PIU including dedicated project coordinator and additional fiduciary and environmental and social support staff; (e) establishment of a geospatial planning platform; (f) hiring of gender-based expert focusing on women’s employment, consumer education and productive use of energy, and (g) related capacity-building and training activities for all key staff in the PIU to support implementation of the project.

Subcomponent 3B: Women’s Employment, Female Entrepreneurship, Consumer Education and Citizen Engagement, and Productive Uses of Energy (SREP Grant US\$0.4 million): The subcomponent will fund the following activities. The subcomponent will fund the technical assistance work centered on enhancing women’s employment in the energy sector focused on key stakeholders such as the MEM, the DoE, and LEC. Limited sex-disaggregated data are available, but global data indicate that women are underrepresented in both technical and nontechnical roles and that the sector is male dominated.

The subcomponent will also fund the development and execution of a community awareness campaign, developed to inform people in target areas of the benefits and costs of electricity services, as well as the payment mechanisms, procedures, and safety practices of the electrification process.

Finally, the subcomponent will focus on closing gender gaps between women and men related to enterprises and livelihoods at the community level.

Component 4: Contingent Emergency Response Component (CERC)

This component covers emergency response through implementation of key activities by appropriate agencies to respond to the emergency. For the Lesotho Energy sector, emergency conditions may arise subsequent to droughts, flooding or energy import shortage.

1.2 DESCRIPTION OF THE PROJECT

The drive behind the project design is to ensure that reliable and affordable power from renewable sources of energy is availed to communities not connected to the national grid. The renewable energy technology has tremendous environmental benefits aiding the reduction in the use of fossil fuels and traditional energy sources from wood.

THE SOLAR MINI-GRID CONCEPT

The concept proposed for the mini-grid project consists primarily of a system for producing electricity that is combined with a storage system for storing the energy produced and a distribution system for supplying energy to isolated loads that are not connected to the national power grid.

The components of a mini-solar grid are depicted in Figure 1-1 and Figure 1-2 below. They include PV panels, solar inverters, housing for the batteries, and plant control systems. Some areas in Lesotho are still not connected to the national grid, PV plants offer a reliable and environmentally friendly solution.

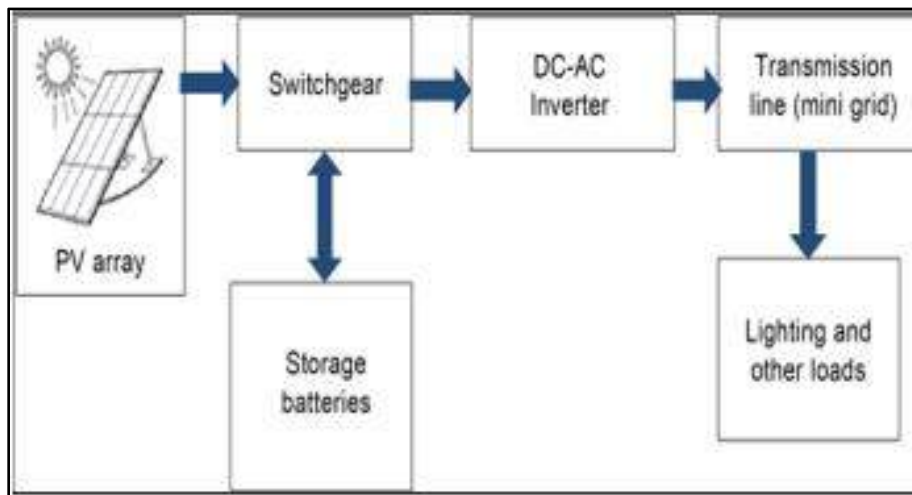

Figure 1- 1: Components of a solar mini-grid¹

¹ Adapted from the PESIA



Figure 1- 2: Illustration of the components of solar mini-grids²

SOLAR PV TECHNOLOGY

The selected Solar PV technology is operated by converting the solar energy from sunlight into usable energy in conjunction with an inverter and other system components. The general makeup of the PV panels is crystalline silicon cells, usually wired in series, and covered in protective glass and encased in a weather and fire-resistant material. To improve the overall system performance, other more advanced systems may implement solar tracking and controls. To ensure continuity of power supply, the mini-grid systems may also have a backup diesel generator. Electricity generated by the plant is distributed to customers via 11 kV feeders, power transformers and LV ABC lines that comply with the Lesotho Grid Code and LEC's network standards.

The mini grids will be built to standards specified by LEWA (LEWA's rural service standards or to Lesotho's grid code standard in order to allow for integration to main grid in the future). Prepaid metering and smart meter systems will be required to mitigate revenue collection risk and enhance the bankability of the mini grid sub-projects.

² Adapted from the PESIA

In the context of a mini-grid, solar PV systems can be installed quickly and easily, and they have a relatively small footprint. In operation, the solar panels at the heart of the system produce no emissions or waste products, and maintenance is limited to periodic checks to ensure they are clean and secure.

An example of a solar PV array comparable to what is expected at the mini-grid site is shown in Figure 1-3.



Figure 1-3: Solar PV array³

In order to determine the technological concept for the solar PV plant, Hybrid Optimisation of Multiple Energy Resources (HOMER) was used to model two systems: one with fixed tilt (FT) mounting and the other with single axis tracking (SAT). The SAT system produces approximately 20% more energy than the FT system, but it requires a larger investment and requires more maintenance due to its moving parts (see Figure 1-4). SAT systems are not only less robust and require more technical expertise for operation and maintenance, but the HOMER simulations also indicate that SAT systems are more expensive to operate and maintain. For this reason, only FT solutions are considered for the solar PV plant.

³ Adapted from the PESIA

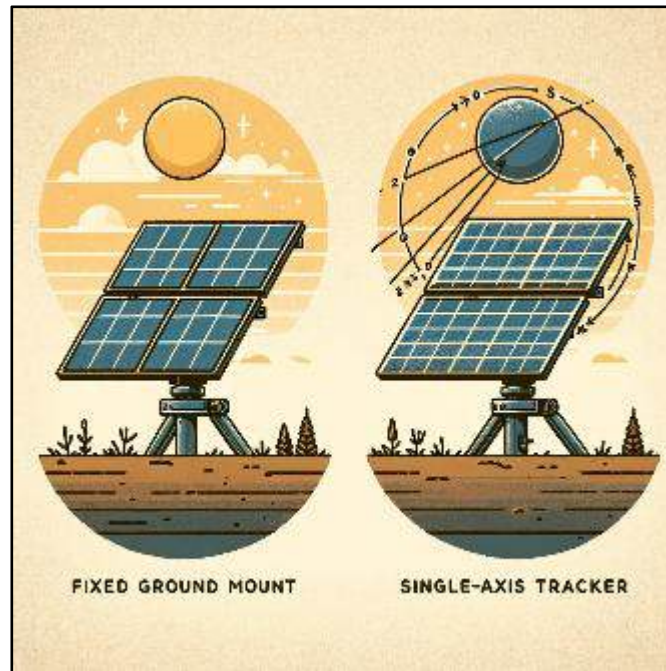

Figure 1- 4: A fixed tilt tracking system versus a solar-axis tracking system (Kristine, 2023)

DISTRIBUTION NETWORK

The distribution network for the Ha Nkau mini-grid encompasses a total length of 9,543 meters for the MV/11 kV portion and 13,287 meters for the LV section. This network is designed to cater to approximately 291 connections, which will be divided among households, public institutions, and small and medium-sized enterprises (SMEs). To ensure efficient power distribution, a total of six transformers will be installed throughout the network. This comprehensive infrastructure will enable the reliable provision of electricity to meet the diverse needs of the community.

The distribution network design is based on ADMD values for a mature mini-grid, and applies LEC's network standards for electrification:

- Fox conductor for the 11 kV feeders
- 4 x 35 mm² and 2 x 35 mm² aerial bundle conductor (ABC) for the low voltage (LV) lines
- 8 mm² Airdac service cable for customer connections.

Customer connections also include a pre-payment meter and circuit breaker in a pole-top box, as well as a Ready board -type distribution board in the customer's premises to enable immediate use of electricity without having to invest in house wiring first.

1.3 LOCATION OF THE PROJECT

The proposed sub-project location is in Ha Nkai which is located in Mohale's Hoek though some of the Ha Nkai enumeration areas are in Quthing. Tentatively, the coordinates for the potential plant location in Ha Nkai are **-30.027410, 28.203208**. Figure 1-5 shows the map for the potential mini-grid location and concession areas.⁴

The selection criteria that prompted the selection of Ha Nkai as one of the mini-grid sites included:

- Distance to the grid (a minimum distance of 15 kilometres from the national grid infrastructure);
- Customer density (high number of potential connections over a broad geographic area);
- Economic centre (households and anchor customers with commercial activity);
- Public institutions (health facility, schools, churches, etc.);
- Clustering (groups of nearby villages); and,
- Access (road access).

⁴ As this is a design-build project, the feasibility study only provides information regarding the potential location of the proposed solar mini-grid. The Developer who shall be engaged must submit final designs illustrating the size of the project's footprint, the area where the mini-grid will be installed, and the system design and length of distribution lines.

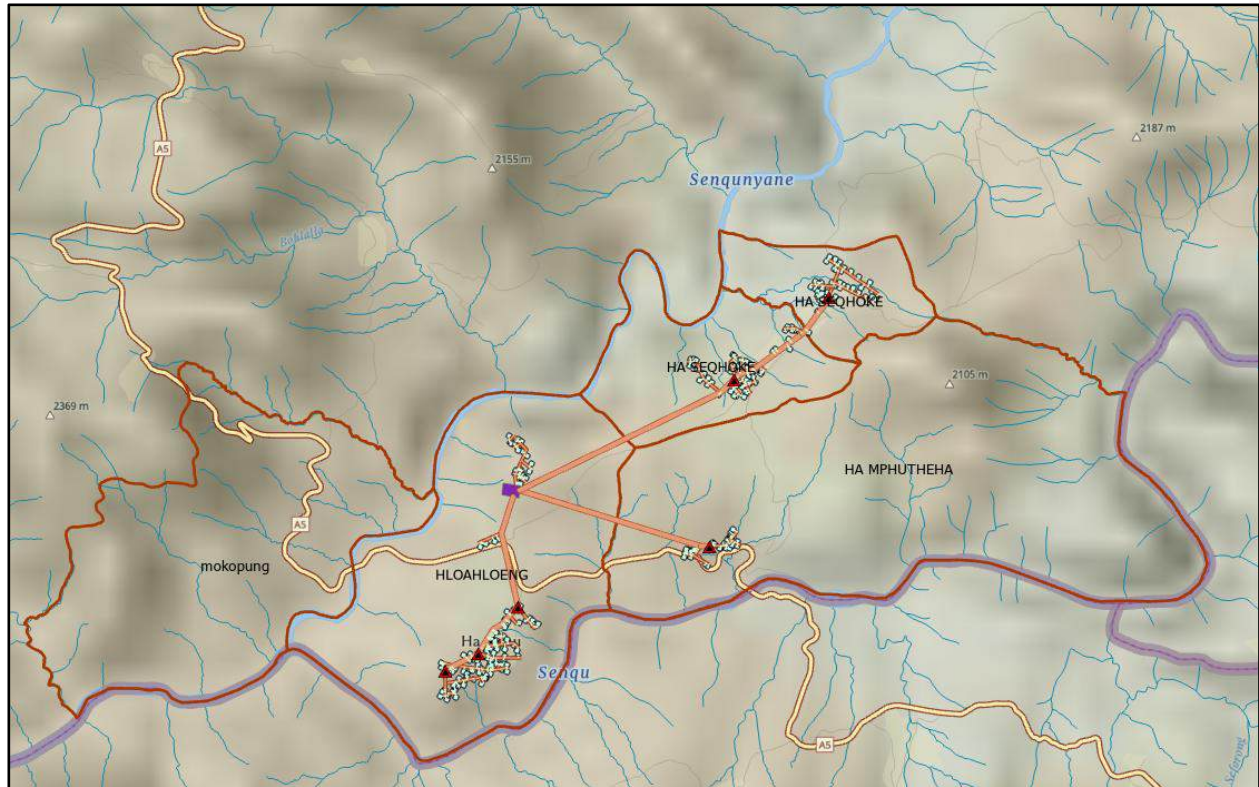

Figure 1- 5: Ha Nkau concession areas

ROAD ACCESS

The current proposed PV plant site at Ha Nkau is accessible hence there will not be a need for construction of an access road to the mini-grid location. It is recommended that animals be used for transportation of poles and other materials for distribution lines in areas where there are no accesses to sub-villages. However, mitigation measures for potential impacts associated with construction of access roads are provided in cases where there may be a need for temporary roads or upgrading of access roads.

LAND AVAILABILITY

Communal land is available for the mini-grid power plant and network installations. Land ownership in Ha Nkau is communal where the area leaders give authority for use of land for development either for domestic, business or institutional purposes. The community seems

receptive to allocate land for the mini-grid project. Presently, part of the land proposed for the mini-grid is used as a football field.

1.4 OBJECTIVES OF THE ESMP

In order to ensure that the environment is protected, an Environmental and Social Management Plan (ESMP) must be developed for all proposed projects, activities, policies or programs which are likely to have adverse effects on the socio-environmental aspects and this project is not excluded.

This Project's ESMP is developed in line with international good practices and the World Bank's Safeguards Policies as well as Lesotho's national environmental legislation, as far as applicable. The World Bank Safeguards Policies require all the bank supported projects to apply the Operational Policy 4.01 – Environmental Assessment. In addition, the Environment Act No.10 of 2008 emphasizes that it is the responsibility of all proponents to observe the environmental laws and regulations and to comply accordingly while implementing developmental activities.

This project ESMP aims to ensure good management practices for the implementation of the proposed development of the Ha Nkai solar mini-grid. It also defines how the management of the socio-environmental risks and impacts are to be reported, and performance evaluated. This ESMP provides rational and practical environmental guidelines for best-practice environmental management. The ESMP will also serve as a reference to LREEAP, key stakeholders and other statutory agencies for monitoring compliance with the national environmental legal framework as well as international best practices. It will ensure that the project adopts a strategic approach to mitigate potential negative environmental, social, health and safety risks and impacts and enhance positive impacts according to national regulatory requirements, particularly, the Environment Act No. 10 of 2008 as well as accepted guidelines and international best practices such as the World Bank Safeguards Policies, and the World Bank EHSGs. The ESMP references and takes cognizance of, where relevant, other documents including Environment and Social Management Framework (ESMF), Preliminary Environmental and Social Impact Assessment (PESIA), Project Implementation Manual (PIM), Resettlement Policy Framework (RPF) and the Project Appraisal Document, that have been prepared for the Project (Also see annexure 11.2).

The specific objectives of the ESMP have been presented in the Figure 1- 6 below.



Figure 1- 6: The specific objectives of the ESMP

2 POLICY AND LEGAL FRAMEWORK

Several policies, legal and administrative frameworks have been developed over the past few years by the Kingdom of Lesotho to guide environmentally and socially sustainable economic development. The policy, legal and administrative framework aims to promote and consolidate sustainable socio-economic development in Lesotho while mainstreaming environmental and social considerations in the sub-project planning and implementation. The following policies, standards and legislation provide the framework within which the environmental and social risks and impacts of the proposed construction of Ha Nkai solar mini-grid will be managed during both construction, operation and maintenance phases.

2.1 NATIONAL POLICIES AND LEGISLATION

2.1.1 CONSTITUTION OF LESOTHO, 1993

Section 36 of Lesotho's constitution makes provision for the protection of the natural environment and states that "Lesotho shall adopt policies designed to protect and enhance the natural and cultural environment of Lesotho for the benefit of both present and future generations and shall endeavour to assure all citizens a sound and safe environment adequate for their health and well-being".

Article 17(1) states that "no property, movable or immovable, shall be taken possession of compulsorily, and no interest in or right over any such property shall be compulsorily acquired.

Section 47, Article 17(2) grants a person with an interest in or right over property that is compulsorily acquired "a right of direct access to the High Court for:

- The determination of his interest or right, the legality of the taking of possession or acquisition of the property, interest or right and the amount of any compensation to which he is entitled; and
- The purpose of obtaining prompt payment of that compensation."

Relevance to the ESMP

The Developer, and Contractor shall ensure that people as well as the natural and cultural environments are protected throughout all phases of the project by adopting policies designed

to enhance the natural and cultural environment for the surrounding community. This shall be achieved by implementation of the ESMP.

The Developer shall also be aware that the law requires prompt payment of compensation for involuntary taking of possession or acquisition of property.

2.1.2 ENVIRONMENT ACT 2008

The Environment Act makes provision for the following principles of environmental management:

- To assure every person living in Lesotho the fundamental right to a clean and healthy environment;
- To ensure that sustainable development is achieved through sound management of the environment;
- To use and conserve the environment and natural resources of the Basotho Nation for both the present and future generations, taking into account the rate of population growth and the productivity of available resources;
- To ensure that waste generation is minimized and safely disposed of.

In addition, the Act prohibits emission of substances which cause pollution in contravention of emission standards. It also prohibits discharge of hazardous substances, chemicals, materials and oils into the environment.

Sections 19(1) and 20 (1) which require preparation of a Project Brief (PB) which entails mitigation measures to offset adverse impacts of proposed from development projects.

Section 25 (1) specifies that no person shall operate, execute or carry out a project or activity specified in the First Schedule without license/approval issued by the Director of the Department of Environment (DoE).

Section 95 of the same Act indicates the need for information dissemination to the public about the project.

Relevance to the ESMP

This ESMP has been developed in fulfilment of the requirements of the Environment Act of 2008. The Contractor shall ensure that the natural resources are used in a sustainable way that does not deprive future generation from benefiting from such resources. The Contractor shall also ensure that waste generation is minimized and safely disposed of.

In order to fulfil the provisions of this Act, it shall be ensured that the public and other relevant stakeholders are engaged throughout the project implementation. For instance, the Contractor shall be in constant liaison with local authorities and hold further public gatherings during commencement of construction and when there is a need.

2.1.3 PUBLIC HEALTH ORDER NO.12 OF 1970

Public Health Order No. 12 of 1970 provides for among others, requirements for human dwellings and operating in healthy housing, including issues of sanitation as a measure of disease prevention, through making accessible to workers safe drinking water and toilets at all times. The Order emphasizes that no person shall cause nuisance or allow nuisance to continue on any land or premises owned or occupied by him or of which he is in charge, which is likely to be injurious or dangerous to health as per section 56 subsection (1)(a) to (r). This Order also has clauses that address issues of waste management at community, business and industrial levels.

Relevance to the ESMP

The Contractor should ensure safe environment for workers through making accessible to workers safe drinking water and toilets at all times. It is also the Contractor's obligation to ensure clean environment around the project area. Hygiene measures such as provision of toilet paper and hand washing facilities should be observed at the construction site.

2.1.4 OCCUPATIONAL SAFETY AND HEALTH ACT, ACT NO.4 OF 2024

The Occupational Safety and Health Act, 2024, builds on the already existing OSH legal provisions for example the Labour Code of 1992, the Mining Safety Act 4 of 1981 and other health laws. Through the Act No. 4 of 2024 all previously fragmented OSH laws are combined into a single comprehensive law applicable to different workplace contexts. The Act seeks to establish an occupational, safety and health management system; promote the development of

a national preventative safety and health culture; ensure a progressive improvement of safety and health of persons at work. The Act also seeks to protect persons, other than persons at work; provide for effective and appropriate compliance and enforcement measures; effect changes required under the relevant international legal instruments; and for related matters. Duties of the both the employer and workers are stipulated in the Act.

Relevance to the ESMP

There is a need for the appointed Contractor to adhere to their duties as stipulated in the Act in the interest of protecting persons at work and other persons from existing risks and hazards posing risks to their health and safety. Application of the Act will aid in the prevention of not only injuries but also deaths in the workplace through the continuous efforts put ensure safe and healthy workplace environments, working conditions and structures, plant and substances designed for use at work. In addition, the workers at the construction sites will also observe their duties as stipulated in the Act.

2.1.5 LABOUR ACT, ACT NO.3 OF 2024.

The Act consolidates all laws relating to labour and employment while also repealing the previously used Labour code of 1992. The Labour Act, 2024 provides a comprehensive framework for regulating the employment relations, promoting fair labour practices and ensuring the welfare and rights of both employers and workers. It also makes provision for ensuring compliance with essential principles and rights at work and other relevant international instruments while promoting the use of best labour practices in the implementation of labour standards and addressing the labour relations contrast between the public sectors and labour relations system by extending coverage to the public sector. The Act has provisions for the prohibition of child labour and sexual harassment.

The Act also covers the working hours in different work sectors, hours of rest as well as the wage structure and the arrangement for shift exchange. Provisions for a wages and conditions advisory board are also provided which enquires into the wages and conditions of employment of any worker in a workplace as may be specified in the Act.

Relevance to the ESMP

The Developer and /or Contractor should as far as reasonably practicable ensure that there is adherence to the relevant labour practices in the interest of ensuring the welfare and rights of not only the employer but the workers also.

2.1.6 ROAD TRAFFIC ACT NO. 8 OF 1981

The Act provides for the registration of vehicles, use of vehicles on public roads and regulation of traffic.

According to Chapter 3 section 20: Certificate of road worthiness will be required for all vehicles to be used in this project. Chapter 8 provides rules of the road that must be adhered to by the construction vehicles and delivery trucks.

Section 58 (1) of this Act prohibits any behaviour by road users which is likely to cause or endanger or obstruct traffic, to endanger persons or to cause damage to public property.

Relevance to the ESMP

The Contractor shall ensure that all vehicles to be used in this project have certificates of road worthiness. In addition, all construction vehicles shall adhere to traffic regulations such as maintaining allowable speed limits. Contractor shall be expected to develop traffic management plan which details traffic control measures around areas of work.

2.1.7 ROAD TRANSPORT ACT NO. 6 OF 1981: PART III; PERMIT

This Act provides for control of road transport through permits:

All material delivery trucks will be required to have a B-permit: a private carrier's permit issued under this Act by the Department of Transport.

Relevance to the ESMP

It is crucial that the Contractor ensures that all construction vehicles and machinery drivers and operators have all the needed permits.

2.1.8 LOCAL GOVERNMENT ACT 1997

Local authorities are amongst others charged with the responsibility of land administration, water supply and public health management. In addition, establishment of local authorities is provided for under the Act with several public/community considerations listed during project construction and operation. It is therefore important to involve local authorities throughout every stage of the project.

Relevance to the ESMP

The Contractor will therefore liaise with local authorities for waste disposal site during construction phase. It is also important to ensure close liaison with local authorities during recruitment of labour from local communities as well as for allocation of land for construction camp, and use of local construction materials such as quarries, sand, etc. In addition, there will be alignment with provisions of the need for community consultations as well as awareness relating to resources under the local Government Authority jurisdiction.

2.1.9 NATIONAL HERITAGE RESOURCES ACT OF 2011

The Act makes provision for the preservation, protection and management of the heritage of Lesotho and for the establishment of the Heritage council and for connected purposes. The act also deals with the conserving of cultural, natural and living heritage of Lesotho. It comprises of all the infrastructure of cultural significance; living heritage; geological sites archaeological; and paleontological sites. Living Heritage simply means immaterial features of the inborn culture. It includes factors such as tradition; oral history; indigenous knowledge; skills and techniques.

Relevance to the ESMP

A chance find procedure has been developed (see annexure 11.6) and the heritage inspector in the office of District Administrator should be informed of any object that is discovered and believed to have any heritage significance with immediate effect. Sensitive cultural norms of the community in the project area should also be respected. The Contractor shall not cause damage to any of the listed items in the Act, including grave yards among others.

2.1.10 LAND ACT (2010)

This Act governs land ownership and occupation, and the acquisition of property for public and development purposes. Sections 53 and 54 make provision for the establishment of public servitudes by the Government, a local Council or a statutory corporation and the payment of compensation. Section 56 stipulates that compensation for compulsory acquisition of property shall be at market value. Section 58 (2) states that “in assessing compensation, regard shall be paid to the value of the property as certified by an odd number of valuers, one of whom shall be the Government valuer, having regard to the present and future replacement value; and to

the expenses incidental to any necessary change of residence or of place of interest.” Section 60 stipulates that that in all cases of compulsory acquisition compensation must be paid before conclusion of expropriation.

Relevance to the ESMP

There should be approval by the responsible authority over provision of titles or subleases to use of land for the development of the mini-grid, including temporary Contractor site camps.

2.1.11 LEGAL CAPACITY OF MARRIED PERSONS ACT (2006)

The Act confers equal powers on both husband and wife married in community of property which means that it gives equal capacity to dispose of the assets of the joint estate, contract debts for which the joint estate is liable and administer the joint estate. This Act requires that both spouses must give consent when entering into any agreements concerning the joint estate. The project will be in line with the provisions of this Act during the compensation process and land acquisitions.

Relevance to the ESMP

In the event where properties are affected, this Act requires that both spouses must give consent when entering into any agreements concerning the joint estate. Thus, during compensation process and land acquisition, the provisions of this Act shall be complied with to ensure that compensations are given equally in the presence of both spouses.

2.1.12 NATIONAL FORESTRY POLICY OF 2008

The Act provides for the sustained management of forests and forest reserves, and for the protection and preservation of forests and forest produce.

Relevance to the ESMP

Due to safety concerns and subsequent public protection, the Project will align itself with the protection of forests, by making sure electricity networks do not run next to or above forests.

2.1.13 GENDER AND DEVELOPMENT POLICY (2003)

In the judicial case of 2003, the government adopted a gender and development policy with emphasis on gender inequality as a major challenge to the empowerment of women. This policy encourages equal participation of women and men in decision making positions at all levels. According to the policy, there is a need to strengthen the linkages between poverty alleviation strategies and equal participation of women and men in decision making positions at all levels of governance. This is a challenge due to patriarchal ideology.

Relevance to the ESMP

There shall be equal opportunities in relation to employment to both men and women. Employment of labourers shall not be gender biased and both males and females will receive fair and equal treatments during construction works. Gender diversity in employment will further enhance collaboration and improve recruitment procedures and reputation of the Contractor.

2.1.14 ENERGY POLICY (2015-2025)

The vision of the policy is that energy will be universally accessible and affordable in a sustainable manner with minimal impact on the environment. One of its goals is to ensure security of energy supplies to meet the national requirements from diversified sources that are subject to local resources, regional agreements and economic feasibility and to ensure that the energy sector will contribute towards poverty alleviation in Lesotho through creation of income generating opportunities that sustain and improve the lives of people in the country through facilitating the provision of affordable technologies and services. The Project is aligned to the vision and goals of the policy as its main objective is to ensure a reliable supply of electricity which will in turn ensure the security of supply and to contribute towards poverty alleviation through economic development.

Relevance to the ESMP

The proposed project will improve reliability and efficiency of energy supply to selected villages thereby improving the efficiency of businesses and lifestyles. Subsequently the project should aim to protect the environment by reducing the reliance on fossil fuels and imported energy thus lessening of Greenhouse Gas (GHG) emissions into the atmosphere.

2.1.15 WORKMEN'S COMPENSATIONS ACT OF 1977

This Act provides for the compensation of workmen for injuries suffered in the course of their employment and to provide for the payment of medical expenses in respect of such injuries and for connected purposes.

Relevance to the ESMP

The project will align itself with the provision of this Act for all concerned (Developer and Contractor and suppliers). There will be workers employed for the project to which the Act will apply. The Developer or Contractor or suppliers will therefore need to ensure alignment with the act in terms of payments which need to be made to register/cover all workers under the compensation fund.

2.1.16 DECENTRALIZATION POLICY (2014)

The policy seeks to deepen and sustain grassroots-based democratic governance while also promoting equitable local development by enhancing citizen participation and strengthening the local government system consequently maintaining effective functional and mutually accountable linkages between central and local government's entities. The specific objectives of the Policy are to:

- i. increase citizens' access to public services;
- ii. ensure quality and accountable service delivery at local levels;
- iii. increase participation of citizens and non-state organizations in governance and service delivery;
- iv. promote equitable economic development;
- v. promote livelihood and economic security;
- vi. enhance local autonomy by ensuring that local government institutions are sustainably capacitated and organised with a strong collective voice;
- vii. promote the preservation of national values, identity and unity by re-positioning and empowering the chieftainship and other traditional institutions.

Relevance to the ESMP

The project will be aligned to the provisions of the policy in a bid to ensure that the policy objectives are attained just as they relate to the project, such as generating and supplying electricity within the community areas. In addition, the project beneficiaries or their elected representatives will actively be included in the decisions pertaining to the subproject as far as reasonably practicable.

2.1.17 NATIONAL STRATEGIC DEVELOPMENT PLAN 2012/13 – 2016/17

This plan sets out the following:

1. Pursue high, shared and employment creating economic growth;
2. Develop key infrastructure;
3. Enhance skills base, innovation and technology adoption for accelerated development;
4. Improve health, combat HIV and AIDS and reduce vulnerability;
5. Reverse environmental degradation and adapt to climate change;
6. Build effective institutions and promote peace and democratic governance.

Relevance to the ESMP

Through the implementation of the ESMP, the project will be aligned to the National Strategic Development Plan (NSDP) goals particularly those relating to infrastructure development, skills development, health improvement and climate change adaptation.

2.1.18 MINI GRID POWER GENERATION, DISTRIBUTION AND SUPPLY REGULATION OF 2021

This piece of legislation has provisions for the promotion, development and utilization of the mini-grid system. According to Section 20(3) a mini grid license shall take reasonable steps in protecting persons and property from injury and damage that may occur because of carrying out the licensed activity.

Relevance to the ESMP

It will be essential for the Developer to comply with the provisions of the regulation as they implement the project. The Developer shall diligently ensure reasonable protection of not only the environment but persons and property as well throughout project implementation.

2.1.19 GUIDELINES FOR EIA IN LESOTHO, 2010

Drawn up with the aim to aid in facilitating participation in and compliance with Lesotho's EIA requirements by the developers. The guidelines provide for the integration of environmental concerns and economic development from the development project's earliest stages.

Relevance to the ESMP

This ESMP has been prepared to assess the impacts and risks associated with the project as well as drawing up the most suitable control measures to each of the identified risks.⁵ In turn, this will facilitate the obtaining of an environmental license for the project.

2.1.20 CUSTOMARY LAW OF 1938 (*MELAO EA LEROTHOLI*)

This is the only written natural law of land in the Kingdom of Lesotho consisting of sets of Customary Laws written in Sesotho which was compiled for the Basotho nation by the Resident British Commissioner of Lesotho on behalf of the Paramount Chief Lerotholi in 1939. Provisions for crop allocation are given in Section 7 of the laws while Section 8 provides for land and property acquisition; stating that, "no one shall be evicted from their home or homestead" unless it is by instruction of a designated court. The rights and obligations of resettled people are provided for in Section 9. Section 31 which refers to reallocation and compensation also provides for allocation and reallocation of land for forestry resources. The customary law along with various other laws have given other functions to the chiefs that include being custodians of the Basotho culture and traditions. The customary law defines the Chief's roles as, "to ensure that the poor, the sick, the disabled and the destitute (including widows and orphans) are provided for by setting aside land to be specifically cultivated for them by the rest of the village."

Relevance to the ESMP

⁵ It is in this regard that the PESIA and this ESMP have been prepared for this mini-grid.

The Developer shall recognise the roles of chiefs in the project in relation to communal issues as well as the rights of those is customary marriages in relation to compensations.

2.2 RELEVANT INTERNATIONAL CONVENTIONS AND STANDARDS TO WHICH LESOTHO IS SIGNATORY

Lesotho is a signatory and party to more than twenty-one international conventions, treaties and protocols. The following protocols are relevant to the Ha Nkau solar mini-grid sub-project.

2.2.1 WORLD BANK SAFEGUARDS POLICIES AND APPLICABILITY

The proposed sub-project is being developed with the support of the World Bank. In developing this ESMP, all environmental and social assessments carried out under this assignment are in accordance with World Bank Operational Policies and the applicable legislative provisions of the Government of Lesotho.

The World Bank Safeguards Policies integrate environmental and social considerations into the planning and implementation of development projects. These policies are designed to:

- (i) Ensure that projects, programs, plans and policies do not negatively affect the environment and society;
- (ii) Managing and reducing risks associated with project implementation;
- (iii) Assist in better decision-making to ensure sustainability of activities. The Bank Safeguards Policies provide guidance to the World Bank on the process, scope and extent of environmental and social assessment required for project evaluation.

In developing this ESMP care has been taken that: “All environmental and social assessments to be carried out under this assignment shall be in accordance with World Bank operational policies and procedures”, with the understanding that, where national legislation does not adequately address issues, the World Bank standards will apply.

The following Operational Policies (OPs) and Bank Procedures (BPs) that are applicable to Ha Nkau Solar mini-grid:

Table 2- 1: OPs and BPs applicable to Ha Nkau solar mini-grid

World Bank Safeguards Policy	Description	Relevance to the ESMP
OP 4.01 Environmental Assessment	Op 4.01 covers impacts on the environment (air, water and land), human health and safety, physical cultural resources, and global transboundary and environmental issues. The project has been classified as Category B in line with OP 4.01.	OP 4.01 is triggered because the Project is likely to have environmental risks and impacts on its area of influence. This policy requires that environmental and social consequences be identified early in the project cycle and considered in the selection, location, planning, and design of the project to minimize, prevent, reduce, or compensate for adverse impacts and thereby maximize positive impacts and include processes for mitigation and management of environmental and social impacts during the project cycle.
OP 4.04 Natural Habitats	OP 4.04 supports the protection, maintenance, and rehabilitation of natural habitats and their functions in its economic and sector work, project financing, and policy dialogue as a result of the likely impacts to natural habitats (such as trees forming forests). The Bank supports, and expects borrowers to apply, a precautionary approach to natural resource management to ensure opportunities for environmentally sustainable development.	The Contractor should ensure that all the project activities promote sustainable use of natural resources and avoid as far as reasonably possible disturbance of ecologically sensitive areas
OP 4.11 Cultural Physical Resources	OP 4.11 provides cultural heritage guidelines to avoid or mitigate adverse impacts of development Projects. This policy applies to the following Projects: (i) any Project involving major excavation, demolition, earthworks, flooding or other environmental modifications; (ii) any project located on or near a site recognized as cultural property; (iii) any project designed to support the management or conservation of physical cultural property. Chance Finds procedures for physical	The Contractor shall ensure that there is preservation of physical cultural resources through implementation of a Chance find procedure (see annexure 11.6) as well as other recommended protection measures for cultural property

World Bank Safeguards Policy	Description	Relevance to the ESMP
	cultural resources will be prepared, if needed: Contractor(s) will comply with these procedures	
OP 4.12 Involuntary Resettlement	OP 4.12 is triggered to address any negative impacts of the potential land acquisition that might cause loss of assets or livelihoods.	Physical displacement is expected for installation of the pv panels, and the building of housing for battery storage and plants controls, and for transmission lines. In accordance with OP 4.12, an Abbreviated Resettlement Action Plan (ARAP) will be prepared. As part of the ARAP, the area of land to be acquired will be determined.

In addition, the following policies and guidelines will also be used:

- The World Bank Group’s Environmental, Health and Safety Guidelines.

The World Bank Group’s (WBG) Environmental, Health and Safety Guidelines also known as the (EHS Guidelines) shall be considered in order to manage the EHS aspects of the project. These guidelines entail technical reference documents with general and industry-specific examples entailing Good International Industry Practice (GIIP). The GIIP are deemed achievable in new facilities at reasonable costs by employing the use of existing technologies.

When host country regulations differ from the levels and measures presented in the EHS Guidelines, project will be expected to achieve whichever is more stringent. If less stringent measures than those provided in the EHS guidelines are deemed appropriate for the project, then a detailed justification must be provided for any proposed alternatives through the environmental and social risks and impacts assessment process. The General EHS Guidelines and the specific EHS Guidelines for Electric Power Transmission and Distribution⁶ shall be

⁶https://www.ifc.org/wps/wcm/connect/topics_ext_content/ifc_external_corporate_site/sustainability-at-ifc/policies-standards/ehs-guidelines

applied to the project. Generally, the EHS guidelines during the construction phase of power transmission and distribution should consider the following:

- **Terrestrial habitat alteration:** The construction and maintenance of a powerline should not pass through forested areas as it may lead to alteration and disruption of terrestrial habitat as well as increased risk of forest fire;
- **Electric and magnetic fields (EMFs):** The Contractor should ensure management of electric and magnetic fields such that they are below the International Commission on Non-Ionizing Radiation Protection (ICNIRP). If the EMF levels are confirmed or expected to be high, modifications can be done on the power line to reduce them either by shielding, burying, or increasing the height of the powerline. However, the sub-project powerline will be 11 kV and 0.4 kV which are expected not to emit EMF level above the ICNIRP standards;
- **Hazardous materials:** there is potential for use of hazardous materials such as insulating oils and fuels, wood preservations and pesticides which should be properly handled and stored throughout the project duration.

2.2.2 THE WORLD BANK GROUP GUIDELINES AND LABOUR INFLUX

These are guiding principles and recommendations to be considered as part of the design and implementation of projects with civil works which require labour from outside of the project's area of influence.

Relevance to the ESMP

This sub-project will require technical skills from outside of the project area and may therefore attract influx of labourers or job seekers.

2.2.3 STOCKHOLM CONVENTION ON PERSISTENT ORGANIC POLLUTANTS

The convention controls management of persistent organic pollutants which accumulate in the atmosphere. Combustion of plastics releases dioxins and furans into the atmosphere.

Relevance to the ESMP

There should not be any burning of plastics at construction sites.

2.2.4 MONTREAL PROTOCOL

This is meant to protect the ozone layer by phasing out the production of a number of substances which are believed to be responsible for ozone depletion.

Relevance to the ESMP

The Contractor to be appointed shall avoid as much as possible the use of ozone depleting substances. The disposal of coolants of refrigerators and air conditioners may lead to leakage of Chlorofluorocarbons (CFCs) if not done properly. Air conditioners can also release CFCs. It is therefore important that disused refrigerators and air conditioners should be disposed accordingly.

2.2.5 SADC DECLARATION ON GENDER AND DEVELOPMENT

This declaration emphasises against discrimination on a person based on gender amongst other things. The declaration also promotes closer regional cooperation and collective action as means of fostering gender equality.

Relevance to the ESMP

The Contractor should ensure inclusion of both men and women during project implementation.

2.2.6 ILO CONVENTIONS TO WHICH LESOTHO IS SIGNATORY

Listed in Table 2- 1 below are the fundamental conventions the ILO has ratified that Lesotho is a signatory to.

Table 2- 2: Fundamental ILO conventions to which Lesotho is signatory

ILO Convention	Relevance
ILO C029 - Forced Labour Convention, 1930 (No. 29)	Labourers shall engage in the project voluntarily for the purpose of this convention in order to suppress compulsory working conditions as a result of deception or coercion, or under threat of penalty or punishment.

ILO C098 - Right to Organize and Collective Bargaining Convention, 1949 (No. 98):	Ensure workers' protection from discrimination for their membership or engagement in union activities.
ILO C100 - Equal Remuneration Convention, 1951 (No. 100):	Employers must provide for equal remuneration for work of equal value independent on whether it is performed by men or women.
ILO C105 - Abolition of Forced Labour Convention, 1957 (No. 105):	Employees cannot be forced to work under discipline or punishment for strikes or for holding certain political views.

2.2.7 CONVENTION ON THE ELIMINATION OF ALL FORMS OF DISCRIMINATION AGAINST WOMEN (CEDAW)

The Convention on the Elimination of All Forms of Discrimination against Women (CEDAW) obligates states parties to ensure gender equality in all spheres of life and protection of women and girls against violence (VAW). Article 12 of CEDAW provides that states parties should take necessary measures to ensure that women have access to the same opportunities as men in employment, promotion, training, equal remuneration, social security and safe working conditions. Women must also be protected in respect of pregnancy, maternity and marital status.

Relevance to the ESMP

The Contractor should ensure that women have equal participation in order to enhance equal opportunity of employment during the implementation phase of the project.

Lesotho is also signatory to the Declaration of the United Nations Conference on the Human Environment, 1992; Rio Declaration on Environment and Development, 1992; and other sustainable development Conventions and strategies pertinent to safeguards policies implications.

3 BASELINE ENVIRONMENTAL AND SOCIAL CONDITIONS

In order to identify baseline environmental conditions and potential environmental impacts, a site visit was conducted to the project area.

3.1 CLIMATE

The project area encompasses the two districts of Quthing and Mohale's Hoek. The climate conditions depicted below are therefore for the two districts (Table 3- 1 and Table 3- 2)

Table 3- 1: Climate conditions for Quthing- Monthly Averages

Month	Jan	Feb	Mar	Apr	May	Jun	Jul	Aug	Sep	Nov	Oct	Dec	Year
Record high °C (°F)	35.0 (95.0)	34.0 (93.2)	34.0 (93.2)	30.0 (86.0)	27.0 (80.6)	25.0 (77.0)	27.0 (80.6)	28.0 (82.4)	32.0 (89.6)	34.0 (93.2)	35.0 (95.0)	34.0 (93.2)	35.0 (95.0)
Average high °C (°F)	23.93 (75.07)	23.97 (75.15)	23.91 (75.04)	20.79 (69.42)	20.02 (68.04)	17.46 (63.43)	17.29 (63.12)	19.6 (67.28)	22.55 (72.59)	23.02 (73.44)	23.04 (73.47)	23.61 (74.5)	21.6 (70.88)
Daily mean °C (°F)	20.07 (68.13)	19.92 (67.86)	19.22 (66.6)	15.85 (60.53)	14.34 (57.81)	11.58 (52.84)	11.87 (53.37)	14.49 (58.08)	17.88 (64.18)	18.42 (65.16)	18.79 (65.82)	19.6 (67.28)	16.84 (62.31)
Average low °C (°F)	11.67 (53.01)	11.43 (52.57)	10.74 (51.33)	7.79 (46.02)	7.04 (44.67)	4.64 (40.35)	4.72 (40.5)	6.41 (43.54)	8.6 (47.48)	8.95 (48.11)	9.37 (48.87)	10.85 (51.53)	8.52 (47.34)
Record low °C (°F)	4.0 (39.2)	4.0 (39.2)	4.0 (39.2)	-2.0 (28.4)	-2.0 (28.4)	-3.0 (26.6)	-4.0 (24.8)	-2.0 (28.4)	1.0 (33.8)	1.0 (33.8)	0.0 (0)	2.0 (35.6)	-4.0 (24.8)
Average precipitation mm (inches)	253.55 (9.98)	225.88 (8.89)	136.49 (5.37)	94.51 (3.72)	24.92 (0.98)	16.56 (0.65)	23.33 (0.92)	23.7 (0.93)	26.29 (1.04)	103.1 (4.06)	127.76 (5.03)	211.01 (8.31)	105.59 (4.16)
Average precipitation days (≥ 1.0 mm)	24.36	20.18	19.27	10.36	5.27	2.55	3.27	4.18	5.55	11.73	15.45	23.18	12.11
Average relative humidity (%)	73.77	74.21	71.7	67.94	57.81	51.19	50.41	45.94	47.12	57.01	65.64	71.12	61.15
Mean monthly sunshine hours	13.08	12.6	10.74	8.6	8.43	8.59	8.53	8.58	10.65	12.64	12.91	13.21	10.71

Source: <https://weatherandclimate.com/lesotho/quthing>

Table 3- 2: Climate conditions for Mohale's Hoek - Monthly Averages

Month	Jan	Feb	Mar	Apr	May	Jun	Jul	Aug	Sep	Nov	Oct	Dec	Year
Record high °C (°F)	37.0 (98.6)	33.0 (91.4)	32.0 (89.6)	30.0 (86.0)	25.0 (77.0)	22.0 (71.6)	22.0 (71.6)	27.0 (80.6)	31.0 (87.8)	34.0 (93.2)	35.0 (95.0)	35.0 (95.0)	37.0 (98.6)
Average high °C (°F)	27.91 (82.24)	26.67 (80.01)	25.33 (77.59)	21.03 (69.85)	18.62 (65.52)	14.78 (58.6)	14.98 (58.96)	18.21 (64.78)	22.78 (73.0)	25.09 (77.16)	26.03 (78.85)	27.26 (81.07)	22.39 (72.3)
Daily mean °C (°F)	24.48 (76.06)	23.23 (73.81)	21.45 (70.61)	17.02 (62.64)	14.11 (57.4)	10.02 (50.04)	10.44 (50.79)	13.66 (56.59)	18.48 (65.26)	21.1 (69.98)	22.3 (72.14)	23.73 (74.71)	18.33 (64.99)
Average low °C (°F)	16.57 (61.83)	15.4 (59.72)	13.32 (55.98)	9.61 (49.3)	7.32 (45.18)	3.59 (38.46)	3.6 (38.48)	5.31 (41.56)	8.76 (47.77)	11.3 (52.34)	12.6 (54.68)	14.97 (58.95)	10.2 (50.36)
Record low °C (°F)	12.0 (53.6)	8.0 (46.4)	5.0 (41.0)	-1.0 (30.2)	-2.0 (28.4)	-3.0 (26.6)	-4.0 (24.8)	-4.0 (24.8)	-2.0 (28.4)	-3.0 (26.6)	2.0 (35.6)	8.0 (46.4)	-4.0 (24.8)
Average precipitation mm (inches)	162.36 (6.39)	146.35 (5.76)	109.9 (4.33)	70.14 (2.76)	25.69 (1.01)	28.39 (1.12)	14.85 (0.58)	16.25 (0.64)	27.15 (1.07)	58.96 (2.32)	121.73 (4.79)	159.9 (6.3)	78.47 (3.09)
Average precipitation days (≥ 1.0 mm)	16.91	14.36	14.36	8.45	4.18	2.45	2.27	2.45	4.64	7.55	10.73	15.45	8.65
Average relative humidity (%)	49.14	53.27	54.28	55.38	51.35	52.1	48.64	38.81	32.69	35.27	41.75	46.86	46.63
Mean monthly sunshine hours	13.64	13.01	11.25	8.98	8.6	8.58	8.59	8.61	10.81	12.8	13.2	13.72	10.98

Source: <https://weatherandclimate.com/lesotho/mohale-s-hoek>

Mohale's Hoek has average maximum and minimum temperature per year, 22.39°C and 10.2°C, respectively. The warmest month of January had a record temperature of 37.0°C while the coolest month of July/August had a record temperature of -4.0°C. The average rainfall in Mohale's Hoek district is 78.47 mm.

Quthing is cooler than Mohale’s Hoek, with an average maximum temperature of 23.93°C in January and an average maximum temperature of 21.60°C in a year. The record low minimum temperature of -4 °C was experienced in July, while the average annual low temperature is 8.54 °C. The average monthly rainfall at Quthing is 105.59 millimeters.

It will be imperative to consider delays that may be brought about by high levels of precipitation and extremely cold weather conditions. Low average precipitation in Ha Nkau area is experienced during the months of June, July and August.

3.2 AIR QUALITY

According to WHO guidelines, the air quality in Lesotho is considered moderately safe with the most recent data showing that Lesotho’s air quality mean annual concentration was 28µg/m3

for PM2.5 which is in excess of the WHO recommendation of 10µg/m³ for that particulate matter.

Majority of the energy sources in the project areas contribute to the excess mean annual concentration of particles and emissions. For activities such as cooking at schools and homes, firewood is a common source. The open burning of firewood contributes to the emission of carbon dioxide, contributing to the greenhouse effect and air pollution. Almost every business in the project areas uses gas for cooking, refrigeration, and heating – Liquefied Petroleum Gas (LPG) has been found to emit small amounts of formaldehyde (HCHO) and nitrogen dioxide (NO₂) according to Bilsback et al., 2019 and Pan et al., 2006).

3.3 FLORA AND FAUNA



Lesotho is predominately a grassland biome with remarkably rich variety of plants and animals. A significant number of plants are endemic to Lesotho (Lesotho Fourth National Report on Implementation of Convention on Biological Diversity, 2009).

3.3.1 FLORA OF HA NKAU

Table 3-3 illustrates the land cover and vegetation in Ha Nkau as observed and reported. Medicinal plants or those that are endangered or nationally protected such as *Dicoma anomala* (*hloenya*), should be rescued and relocated during excavations in cooperation with local communities.

Table 3- 3: Land cover and vegetation at Ha Nkau

Description: Land Cover and Vegetation at Ha Nkau	Photographic Record
---	---------------------

Description: Land Cover and Vegetation at Ha Nkau	Photographic Record
<ul style="list-style-type: none"> - <i>Gazania krebsiana</i> (<i>tsikitlane</i>) shown in shown in Figure 3-1 which was used traditionally to make clothing (such as skirts <i>thethana</i>), was vast in this area, especially around Seforong. Also, <i>Agave Americana</i> (agave) was prominent in this area. - There was also some appearance of <i>S. runcinata</i> (<i>mosisili</i>) shown in Figure 3-2 in some areas, especially the area chosen to host the solar mini-grid. Medical applications of this plant include respiratory, circulatory, and reproductive conditions. Other observed plants included <i>Euphorbia clavarioides</i> (<i>sehloko</i>) shown in Figure 3-3. - <i>Pinus</i> (Pine) trees have been planted in the area, while most of the land was covered in shrubs and grass; <p>Reported medicinal flora in the area includes:</p> <ul style="list-style-type: none"> - <i>H. caespititium</i> (<i>phate-ea-ngaka</i>), <i>Talinum caffrum</i> (<i>phonyoka</i>), <i>Dicoma anomala</i> (<i>hloenya</i>), <i>Schkuhria pinnata</i> (<i>letapisa</i>), <i>H. geniculata</i> Eckl. (<i>selepe</i>), <i>Salvia repens</i> (<i>mosisili</i>), <i>H. odoratissimum</i> (<i>phefo</i>), <i>Artemisia afra</i> (<i>lengana</i>). 	 <p style="text-align: center;">Figure 3- 1: <i>Gazania krebsiana</i> (<i>tsikitlane</i>) at Seforong</p>  <p style="text-align: center;">Figure 3- 2: <i>S. runcinata</i> (<i>mosisili</i>) observed at Ha Nkau</p>

Description: Land Cover and Vegetation at Ha Nkau	Photographic Record
	 <p data-bbox="769 894 1273 924">Figure 3- 3: <i>Euphorbia clavarioides (sehlooko)</i></p>

3.3.2 FAUNA

The fauna present in the project area is primarily composed of domesticated animals including, cattle, sheep, goats, horses, donkeys and dogs. There were reports of other wild animals that were not seen, as well as large and small birds observed flying, but many of them could not be identified. The wild animals reported include black backed jackal, rock rabbit, grey rhebuck and wild cats.

The construction phase of this project may adversely affect a number of bush and forest dependent species due to excavations for access roads and digging for poles. Some species of larger, heavier birds are susceptible to collisions, while several species are also electrocuted when perching on, roosting on, or nesting on infrastructure. It is therefore essential to plan and design routes in order to avoid areas such as birds’ habitats.⁷ Where possible, the Contractor should use powerlines with a larger diameter which increases the visibility of the powerlines to the avifauna.

⁷It is advised that there be consultation with local avifauna experts for guidance such as Quthing Wildlife Development Trust and Bearded Vulture National Task Team

Powerline towers/structures should also be strategically situated to avoid burrowing or excavating animals, as these can destabilize the structures and eventually lead to their collapse.

3.3.3 INTERNATIONAL UNION FOR CONSERVATION OF NATURE (IUCN) STATUS OF SPECIES IDENTIFIED AT HA NKAU

The table below represents the IUCN status of species found at Ha Nkau.

Table 3- 4: IUCN status of species found at Ha Nkau

Flora and Fauna Species at Ha Nkau	IUCN Status
<i>Agave vizcainoensis</i> (agave)	LC
<i>Euphorbia clavarioides</i> (sehloko)	Status could not be found
<i>H. caespititium</i> (phate- <i>ea-ngaka</i>),	LC
<i>Talinum caffrum</i> (phonyoka),	Status could not be found
<i>Dicoma anomala</i> (hloenya),	VU
<i>Schkuhria pinnata</i> (letapisa)	NE ⁸
<i>H. geniculata</i> Eckl. (selepe)	LC
<i>Salvia repens</i> (mosisili)	NE
<i>H. odoratissimum</i> (phefo), <i>Artemisia afra</i> (lengana)	NE

IUCN- SPECIES CATEGORIZATION

⁸ *Schkuhria pinnata* only found Global Conservation Status according to NatureServe not IUCN

EXTINCT (EX), EXTINCT IN THE WILD (EW), CRITICALLY ENDANGERED (CR), ENDANGERED (EN), VULNERABLE (VU), NEAR THREATENED (NT), LEAST CONCERN (LC), DATA DEFICIENT (DD), NOT EVALUATED (NE)⁹

3.4 WATER RESOURCES

Lesotho has abundant water resources that exceed requirements for possible future irrigation projects development. The total water consumption in Lesotho is about 2 m³/s while the total availability is about 150 m³/s, (<https://www.water-technology.net/projects/lesotho-highlands>). According to Leketa, *et al.*, 2018, the surface water hydrology of Lesotho is defined by three major rivers namely Mokhotlong in the far west, Makhaleng in the central area and Senqu in the Far East.

Water resources observed at Ha Nkai include Senqu river Figure 3-4 flowing adjacent to Ha Nkai village and which is one of the three main river systems in Lesotho. A tributary of Senqu river – Senquyane is also in the vicinity of Ha Nkai. In addition, there were other small streams in Ha Nkai feeding into the Senqu River.



Figure 3-4: Senqu River cutting through Ha Nkai project villages

The Contractor should consult with local authorities and the Department of Water Affairs to obtain the necessary licensing for sourcing water from different water sources. In the design

⁹ <https://www.iucnredlist.org/>

and construction of this project, wetlands and swamps shall be avoided as far as reasonably possible.

3.5 GEOLOGY, GEOMORPHOLOGY AND SOIL TYPE

The geological composition of the area consists of yellowish-brown weathered hard sandstone (Figure 3-5), which may pose challenges during excavation. In order to effectively carry out the construction activities, the Contractor might need to utilize drilling techniques to facilitate the process. Additionally, the soil in this region is predominantly sandy, accompanied by loose weathered rock materials and pebbles. Given this composition, it becomes crucial for the Contractor to implement appropriate erosion prevention measures to safeguard the integrity of the soil.



Figure 3- 5: Yellowish hard sandstone rock

3.6 CURRENT LAND USE

Maize fields were a prominent feature in the area, indicating the significance of agriculture in the region. Alongside the agricultural landscape and residential areas, there were various establishments such as shops and institutions, suggesting a level of economic activity and community development within the villages. Additionally, the practice of farming at homesteads was observed, particularly in the cultivation of vegetables like spinach as shown in Figure 3-6. Furthermore, the region also consisted of rangelands, underscoring the importance of livestock farming and the utilization of natural resources for sustenance.



Figure 3- 6: Green vegetables subsistence farming at Ha Nkau

Heavy construction vehicles may traverse the fields and temporarily suspend the use of the land for crop production. For this reason, the Contractor should avoid traversing fields and using uncultivated areas for access roads as far as reasonably possible. It is also necessary to adjust the poles’ location in order to minimize the impact on agricultural operations. In order to minimize crop damage, it may be necessary to delay construction in agricultural areas until after harvest.

3.7 INFRASTRUCTURE AND SOCIOECONOMIC CONDITIONS

The PESIA shows that although Lesotho heavily relies on imports as it produces less than 20% of the nation’s demand for food, a significant amount of people live in the rural areas herding animals and conducting subsistence farming. The weather and climate variability leaves the agricultural sector in Lesotho rather vulnerable.

Rural areas in Lesotho often have limited infrastructure and limited resources. This can be seen in Table 3- 5 which presents the socioeconomic and infrastructure conditions in Ha Nkau.

Table 3- 5: Socioeconomic and infrastructure conditions in Ha Nkau

Description – Socio-economic conditions and infrastructure	Photographic Record
--	---------------------

- A paraffin tank was in place for selling paraffin to the locals, close to the clinic;
- There was a solar powered borehole close to the Health Centre at Ha Nkai;
- There was a failed spring at Ha Nkai village resulting in critical water challenges;
- Department of Rural Water Supply (DRWS) tank and taps were present at Ha Nkai most villages;
- There was a borehole powered by solar (Figure 3-7) close to the Health Centre;
- There were small retail shops, a Health Centre, a number of schools high school including Hareeng High School (Figure 3-8) and a number of churches.



Figure 3-7 Solar panels for pumping water out of the borehole at Ha Nkai



Figure 3-8 Hareeng Combined School at Ha Nkai

Whenever possible, the Contractor will source labour locally, support local businesses, and improve local infrastructure in order to boost local spending. Growth in income is closely related to the development of electricity infrastructure hence the project will improve the socio-economic conditions of the project areas.

It is important to note that access to the majority of the project areas is notably difficult and some of sub-villages are not accessible by motor vehicles. Therefore, there may be a need to construct temporary access roads in Ha Nkai in order to facilitate transportation of materials or make use of animals and people for transportation of materials.

3.8 ENERGY SITUATION

Sustainable Development Goal (SDG) No.7 which Lesotho subscribes to seeks to ensure that access to affordable, reliable, sustainable and modern energy is made for all. In order to make this a reality, target 7.1 is set to ensure universal access to affordable, reliable and modern energy services by 2030. As a lower income country, Lesotho naturally has a major percentage of electrical access concentrated in urban areas where electrical infrastructure is considerably developed rather than in the rural areas. By percentage, about 47% of the urban areas have access while for the rural areas roughly 10.2% of the areas are grid-served (UNEP, 2017). The terrain of the country and low population density have over the years threatened efforts to extend the grid (The World Bank, 2020). The utility services are therefore more focused in the lowlands rather than the highlands.

A baseline study report prepared for the Lesotho Energy Access Strategy Project in 2007 showed that paraffin is widely used in almost all household followed by wood, shrubs, dung and crop residues. The same report showed that though there is use of solar for heating and lighting in some households, the uptake is generally low as huge costs are involved in its installation. This is also congruent with the observations made on the energy situation during stakeholder consultations in the different enumeration areas. Some of the energy sources shown to be in use by institutions at Ha Nkai are presented in Figure 3-9. In Ha Nkai, majority (67 %) of the institutions in the village use solar and battery lights while 33% of them use firewood and another 33% use gas. Generators are used by 33%. Candles, cow dung, coal and paraffin are less common in Ha Nkai institutions though their usage may be more prevalent at household level.

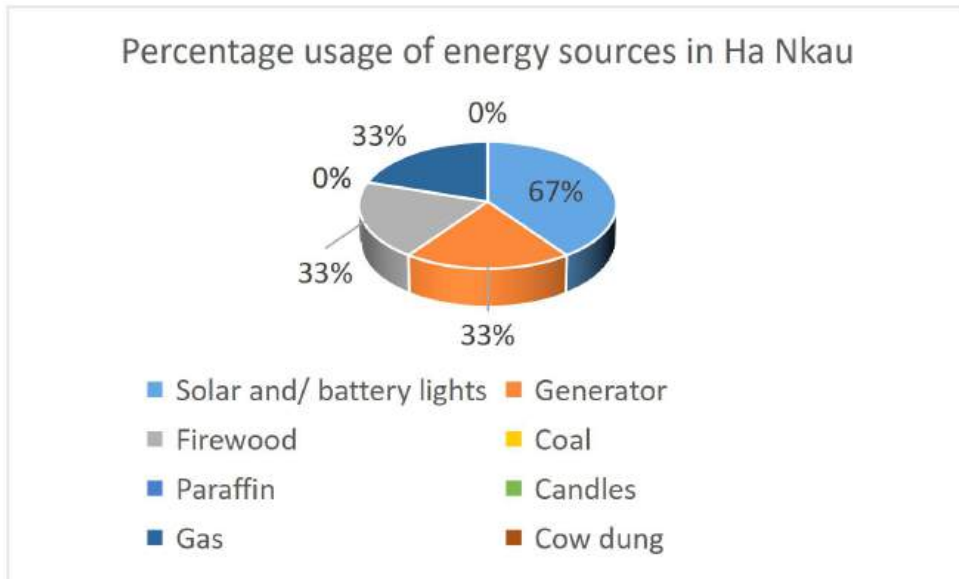

Figure 3- 9 : Ha Nkau percentage usage of energy sources

4 POTENTIAL ENVIRONMENTAL AND SOCIAL RISKS AND IMPACTS AND MITIGATION MEASURES

There are a number of potential environmental and social risks and impacts (biophysical and socio-economic) that may result from implementation of the proposed sub-project. These include both positive and negative impacts on different aspects of the bio-physical environment as well as social aspects. Impacts that may arise from the project during pre-construction phase, construction phase, operation and maintenance phase are described in the sections that follow.

4.1 IMPACT ASSESSMENT METHODOLOGY

The methodology presented in annexure 11.3 outlines the steps that are taken to assess the potential environmental, social, and health and safety risks and impacts of a proposed subproject. This commenced with literature review which involved review of documents relevant to the proposed development. Literature review was a continuous exercise and it involved the review of: Project documentation including review of the Environmental and Social Management Framework (ESMF) and the Terms of Reference (TORs) for the construction of ten (10) solar mini-grids, Preliminary Environmental and Social Impact Assessment (PESIA), Project Implementation Manual (PIM), Resettlement Policy Framework (RPF) and the Project Appraisal Document, that have been prepared for the Project.

4.2 DESCRIPTION OF POTENTIAL PROJECT IMPACTS AND PROPOSED ENHANCEMENT/MITIGATIONS MEASURES

The PESIA identified potential socioeconomic risks and impacts for Ha Nkau mini-grid to include the following:

- Potential loss of small areas of land;
- Low resource base or poor cash flow;
- Insecurity of property;
- Impact of HIV/AIDs and;
- Lack of and poor access roads.

For the biophysical risks and impacts, the PESIA states site specific risks and impacts that include

- Soil erosion;
- Localised and intermittent noise;
- Localised and intermittent airborne dust generation;
- Soil and water pollution; and
- Visual impact of transmission infrastructure located on high ground.

It is noteworthy that Ha Nkau is considered to have a high risk of insecurity of project property.

Table 4-1 to Table 4-3 provide the description of potential environmental, social and health and safety risks and impacts as well as their significance ratings for all project phases. The impact significance assessment is based on extent, duration, magnitude, reversibility and likelihood of the impact. The environmental and social significance of the identified impacts has been identified for the time before implementation of mitigation or enhancement measures and post implementation of mitigation measures as shown in Table 4-4 to Table 4-6 .

Pre-mitigation ratings are estimates based on the criteria after comprehending a risk and developing a risk description (Extent, duration, Intensity, reversibility and probability). In this process, the possibility and impact of the risk are estimated in relation to the project's present goals and plan. This is followed by the identification of proactive mitigation actions that reduce the risk probability and/or impact by addressing sources of risk or planning a fall-back. Finally, re-estimation of the risk on the basis that all the identified mitigation actions that have been authorised will be implemented as planned – post-mitigation rating.

For example, in terms of the impact of site clearing for camp site establishment, vegetation clearance is most likely to occur during the pre-construction period for site camp setup. However, the suggested mitigation measures, such as limiting vegetation removal to where necessary, will result in reduced magnitude and extent scores. Lowering these scores will result in a lower post-mitigation score. However, durations and probabilities may stay constant for the pre and post-mitigation stages. In terms of noise and air pollution, for instance, their generation is unavoidable. However, with the provided mitigation measures such as dust suppression, servicing construction vehicles and restricting noise beyond working hours, the magnitude, extent and duration of the impact will be less.

4.2.1 ENVIRONMENTAL (BIOPHYSICAL) RISKS AND IMPACTS

Table 4- 1: Description of potential environmental risks and impacts for different phases of the project

IMPACT	STATUS	ACTIVITY	DESCRIPTION	IMPACT SIGNIFICANCE
ENVIRONMENTAL/ BIOPHYSICAL IMPACTS				
Loss of vegetation	Negative	Site preparation and site clearance;	<p>Preconstruction phase</p> <p>The clearance of vegetation is most likely to occur during the pre-construction phase. This could be due to the preparation of the land for camp site establishment and area that the solar panels will erected. This may result in biodiversity reduction. Any ecosystem fragmentation will possibly bring changes in the richness and abundance of such plant species thereof. This will in turn bring about a variance in species diversity among the Ha Nkau village – enumeration areas.</p>	Medium [50]
		Camp site establishment;		
		Excavations;		
		Construction of access roads	<p>Construction phase</p> <p>There will also be clearing of vegetation during construction of access roads, clearing for the plant (PVC areas and powerhouses) and minor excavations for distribution lines.</p>	Low [30]

IMPACT	STATUS	ACTIVITY	DESCRIPTION	IMPACT SIGNIFICANCE
Exacerbated soil erosion	Negative	Establishment of a camp; Construction of access roads; Clearing and excavations.	Construction phase Road construction is characterised by excavations which if not controlled may lead to soil erosion as soil is left exposed; The soil structure also gets disturbed during site clearing and excavations for poles thereby leaving the soil vulnerable to erosion.	Medium [60]
			Operation phase If there are no buffers provided for the area apportioned for erection of the solar panels, loose soil may still be at risk of being eroded	Medium [40]
Loss of environmental aesthetics	Negative	Design and structures	Preconstruction and construction phase Construction activities and temporary accommodation facilities alter the aesthetics of the project site which may not be appealing to some project affected people.	Medium [35]
			Operation phase Visual aesthetics of the area may be altered. Solar panels and cleared tracts of land will be visible in an area previously dominated by vegetation.	Low [30]

IMPACT	STATUS	ACTIVITY	DESCRIPTION	IMPACT SIGNIFICANCE
Soil and water pollution	Negative	Excavations; Removal of topsoil; Concrete mixing/batching; Vehicles repair; Fuel storage;	<p>Construction Phase</p> <p>Petroleum containing products may be spilt during vehicle repairs and fuel storage. These have a potential to pollute both ground and surface water sources as well as the soil. Soil from the excavation may be washed away into water bodies so that sediments accumulate in the water bodies close to the excavation sites.</p>	Medium [39]
		Wastewater and effluent generation. Stockpiling and disposal of obsolete batteries	<p>Operation and maintenance</p> <p>The severity of soil and water pollution is limited unless if there are accidental leakages or spills of oils used in the plant or fuel kept for the backup generator. These may contain hydrocarbons which can alter soil composition in turn affecting vegetation growth. The same hydrocarbons from the oil and fuel spills may also pollute both ground and surface water.</p> <p>Throughout the operation and maintenance of the solar system, system components may require replacements to ensure efficiency Ideally, batteries have to be replaced every 5 to 7 years. The process of replacement generates e-waste which if indiscriminately disposed of has the potential to pollute both the soil and water.</p> <p>Construction and operation and/or maintenance activities have a potential to generate wastewater aside from the wastewater from the ablution facilities. These activities</p>	Medium [39]

IMPACT	STATUS	ACTIVITY	DESCRIPTION	IMPACT SIGNIFICANCE
			<p>include and are not limited to; discharge of water used in concreting and demolition, washing of construction materials, cleaning of tools and equipment, airlifting process for cleaning bore piles. Waste water may pollute the soil in turn bringing about pollution of both ground and surface water sources.</p>	
			<p>Closure phase</p> <p>Obsolete batteries as well as other out-of-date electrical equipment such as transformers, circuits and cables will impact on natural ecosystems elements that is, the natural vegetation and biodiversity if indiscriminately disposed of. The batteries are made of lead compounds which are detrimental to human and environmental health. Cadmium may pose risks if solar units are not disposed-off properly.</p>	Medium [52]
Waste generation	Negative	<p>Generation or accumulation of waste during different activities</p> <p>General</p>	<p>Construction phase</p> <p>Waste will be generated during the construction phase. Some of the waste generated will include packaging materials of PV panels, battery banks, combiner boxes, paper, wood, cement bags, plastic, and mud, whereas batteries (after used period about 15 years), scrap metals, sharp objects broken glass, absorbent material, etc. Domestic waste will also be generated by people in the camp and amount of waste they will generate will be dependent on the number of people living in such camps thereof. Indiscriminate management of these waste streams could have cause water and land pollution, reduce environmental aesthetics as well as causing impacts on health and safety of workers as well as the general public.</p>	Medium [52]

IMPACT	STATUS	ACTIVITY	DESCRIPTION	IMPACT SIGNIFICANCE
		operation and maintenance works	Operation and maintenance and closure phases Throughout the operation phase domestic waste will be generated. The repairs and maintenance work conducted will result in the generation of waste electrical and electronic equipment (WEEE). This will include e-waste from replacement of batteries and other electrical equipment.	Low [24]
		Replacement of batteries and other equipment		Closure phase Excavation waste, debris and demolition waste is generated during demolition in the closure phase. Out of date panels will also form part of demolition waste
Air pollution	Negative	Transportation;	Construction phase Construction activities for this project will not cause significant air quality change and any possible changes in air quality will likely be temporary and localised. Earthworks activities such as levelling, grading, excavation works and movement of vehicles in dusty roads, especially during windy conditions will have an impact on the quality of air. In addition, cement dust in construction sites will also alter the quality of air. Burning of construction waste such as plastic releases noxious gases which also influences air quality.	Low [28]
		Drilling where there is hard rock; Excavations. Construction of access roads		Operation and maintenance

IMPACT	STATUS	ACTIVITY	DESCRIPTION	IMPACT SIGNIFICANCE
		Demolition activities	There is limited potential for air pollution during this phase that maybe from exhaust fumes from vehicles and machinery used during maintenance works.	
			Closure phase Heavy vehicles and machinery produce exhausts and these emissions will lead to air pollution. Demolition activities also generate dust which can affect air quality.	Medium [40]
Noise pollution	Negative	Transportation; Drilling where there is hard rock; Excavations Construction of access roads	Construction phase Construction equipment is known to generate noise. Although non-intensive construction will be done, the machinery, construction activities and or equipment used will likely generate noise which can pose as a nuisance to communities in close proximity to the construction sites. Some of the noise generating activities will include earthworks and excavation (for land levelling), material haulage, backfilling and installation of PV modules, and other equipment as well as powerhouse construction.	Low [28]
		Increase in economic activities conducted	Operation and maintenance phase Noise may be generated from maintenance works and vehicles which will be involved in the operation of the mini-grid. With the increase in economic growth comes an increase in activities that can pose a threat to air quality. For example, there may be more beerhalls where liquor is sold and loud music is played. Service stations and	Low [18]

IMPACT	STATUS	ACTIVITY	DESCRIPTION	IMPACT SIGNIFICANCE
		Demolition activities	garages too may increase in number. This is an indirect impact and noise generated in these places is however not as significant as the one from construction activities.	
			<p>Closure phase</p> <p>Demolitions works (which will be dependent on how the project site will be repurposed), machinery operations, and heavy truck movements may result in noise disturbance during demolition.</p>	Medium [40]
Generation and exposure of hazardous waste oils/chemicals and e-waste	Negative	Various construction activities	<p>Construction phase</p> <p>Some of the construction equipment used will need either fuel or some oil for operation. In instances where such hazardous material spills or leaks it can be washed away into the environment such that water and soil pollution may occur.</p>	Medium [44]
		Maintenance activities and operation of petroleum fuel powered	<p>Operation and maintenance phase</p> <p>In cases of physical damage occurring to the batteries or panels or after their expected lifespan, disposal will have to be done. The accumulation and disposal of this hazardous waste can lead to pollution of the receiving environment. Essentially, solar batteries require replacement after every five years while the PV panels can be replaced after 25 years.</p>	Medium [40]

IMPACT	STATUS	ACTIVITY	DESCRIPTION	IMPACT SIGNIFICANCE
		equipment Demolition	Closure phase Improper disposal of batteries and panels after their life-time can potentially lead to health risks.	Medium [40]
Natural risks/disasters / weather elements	Negative		Construction/ operation and maintenance phases The proposed development can be affected by risks associated with the effects of climate change and weather elements such as risks associated with heavy rains. Effects of climate change could bring about increase in weather conditions which impact construction activities or reduce sunlight absorption by the solar panels. For example, instances where there are more cold weather days or days that there is heavy rain. On such bad weather days little to no sunlight absorption will occur which in turn reduces amount of energy that can be stored and distributed to the end users.	
Avian collision and electrocution	Negative	Electricity distribution lines	Operation and maintenance phase Existence of distribution lines and solar panels fragment the natural habitats of different avian species. They may be erected along the migration routes of large birds without mitigation or avoidance measures thereby leading to mortality of birds, some of which may be endangered.	Medium [48]

IMPACT	STATUS	ACTIVITY	DESCRIPTION	IMPACT SIGNIFICANCE
Environmental conservation	Positive	Use of an energy efficient fuel	Operation phase Reduction in the reliance on fossil fuels through the provision of a clean source of energy in turn reducing carbon and nitrogen emissions.	Medium [36]

4.2.2 SOCIAL AND ECONOMIC RISKS AND IMPACTS

Table 4- 2: Description of potential social risks and impacts for different phases of the project

IMPACT	STATUS	ACTIVITY	DESCRIPTION	SIGNIFICANCE
SOCIOECONOMIC IMPACTS				
Loss of livelihoods/ property/ land/ relocation of community utilities	Negative	Land acquisition and use for installation of poles, campsite establishment and trampling. Construction plant and distribution lines	<p>Preconstruction</p> <p>Ha Nkau location is currently being used as a football pitch. There is therefore a risk of social displacement from land needed for the project.</p>	Medium [40]
			<p>Construction</p> <p>During the installation of poles and cables, temporary access restrictions to properties/community buildings may exist. Trees may also need to be cut down to construct the distribution network/power generation assets.</p>	Medium [40]
Employment creation and skills development	Positive	Hiring and /or labour recruitment	<p>Preconstruction phase</p> <p>For construction activities on site, labourers will be needed many of which can be sourced locally. Local sourcing of labourer allows for mitigation of possible influx of job seekers. Ideally, sourcing of labourers should be done in consultation with local authorities, giving a fair chance of employment to all the locals both male and female.</p>	Low [21]
			<p>Construction phase</p> <p>The proposed project will potentially create jobs. Employment during the construction</p>	Medium [45]

			<p>phase will be dependent on the nature of work that needs to be done. The engaged Contractor will determine the number of employees needed in consultation with both the local authorities. This will therefore ensure that there will be skills development for people who will be employed during construction phase. These individuals that receive skills training will also be employable in other similar projects.</p>	
			<p>Operation and maintenance phase</p> <p>Employment during the operation phase is anticipated for both skilled and unskilled labour. Skills development will therefore occur for people who will be employed during operation phase. Individuals who will gain skills from this project will be more employable in similar projects hence the project will also have indirect positive impacts.</p>	Low [18]
Change in demographics	Negative	Hiring or labour recruitment	<p>Construction phase</p> <p>Job seekers will be attracted to the project areas during the construction phase and this has an impact on the project area demographics. Change in demographics may in turn prompt the increase in the spread of HIV in areas with high influx of job seekers as they tend to form sexual relationships with locals. Influx of job seekers also leads to increased crime rates as job seekers are idle and in need for survival. In addition, increase in the number of people within the villages due to construction will also exert pressure on existing services.</p>	Medium [36]
	Neutral	Migration to project areas	<p>Operation and maintenance phase</p> <p>Presence of electricity in project areas will lead to increased number of households settling in them thereby changing demographics. Change in demographic leads other socio-economic impacts and benefits. Negative impacts of change in demographics include increased HIV infections and stress of services such as water supply. Positive impacts/benefits include growth in localised economic activities leading to improved</p>	Medium [40]

			<p>livelihoods.</p> <p>Limited labour influx will occur once the project is in its operation phase. Human resources that will be needed will include operators and support staff based on availability and different skills set needed.</p>	
Trafficking in persons (TIP)	Negative	Recruitment	<p>Construction phase</p> <p>The rate of unemployment forces the job seekers to be taken advantage of. Human traffickers may deceive job seekers by promising them non-exist jobs.</p>	Low [24]
Social exclusion: Inability to connect to the mini-grid	Negative	Distribution of electrical power to houses, retail and institutions;	<p>Operation phase</p> <p>Although tariffs may be subsidized for the different rural communities to encourage access to electricity, some households may still not afford the subsidized prices. The ability to pay for a considerable portion of rural households is low.</p>	High [65]
HIV/AIDS, GBV AND SEA/SH	Negative	Hiring or labour recruitment.	<p>Construction phase</p> <p>Creation of employment may cause people to leave their homes and temporarily stay in areas easily accessible to the project area where they can be closer to their work place. This may cause job seekers and migrant workers to form sexual relationships outside their families thereby increasing chances of HIV infection. Presence of migrant workers and job seekers in rural communities can also lead to moral degradation in communities.</p> <p>Construction projects have a potential to increase the number of males in the community which may lead to increased GBV/SEA/SH in the community. With no mitigation, GBV/SEA/SH incidents may also be experienced at work.</p>	High [68]
Impact on	Negative	Excavations;	<p>Construction phase</p>	Low [27]

physical archaeological or areas of cultural significance		Installation of electricity utility poles; Trampling during transportation	The project has a potential of affecting sensitive areas such as graveyards. This may cause conflicts between the Contractor and community as culturally there is a special respect and honour for the dead hence respect for the graveyards. All the archaeological areas and areas of cultural significance should be a no-go area. However, in unlikely cases where graves need to be relocated, it should be in consultation with local authorities and families of the deceased.	
Conflicts and project grievances	Negative	Recruitment	<p>Pre-construction phase</p> <p>The recruitment process could lead to the onset of conflicts. These conflicts may arise between the Contractor and locals particularly where there is an element of exclusion of the locals in the hiring process or where no fairness exists in recruiting the locals. Conflicts may also exist among the Contractor employees. In addition, there may be conflicts related to compensation issues in relation to land acquisition.</p>	Low [30]
			<p>Construction phase</p> <p>The recruitment process could lead to the onset of conflicts. These conflicts may arise between the Contractor and locals particularly where there is an element of exclusion of the locals in the hiring process or where no fairness exists in recruiting the locals. Conflicts may also exist among the Contractor employees. In addition, there may be conflicts related to compensation issues in relation to land acquisition.</p>	Low [27]
Theft/	Negative	Installation of	Construction phase	Medium [40]

Vandalism		electrical infrastructure	A market for the electrical equipment exists. As such, thieves may be drawn to the mini-grid site to steal electrical equipment for purposes of reselling.	Medium [40]
			<p>Operation and maintenance phase</p> <p>Herd boys and other children may throw stones on the solar panels which may destroy them in one way or the other.</p>	
Community health and safety: Improved health and safety	Positive	Distribution of electrical power to houses, retail and institutions;	<p>Operation and maintenance phase</p> <p>With the provision of electricity, medical equipment can be powered as well as preservation of drugs and food for longer periods of time.</p> <p>In instances where communities were used to using naked flame for lighting, electrical bulbs present effective substitutes of paraffin lamps and candles which can be associated with multiple health issues (lung malfunction and cancer) and fire risks.</p>	Very low [15]
Improved accessibility to a reliable source of energy	Positive	Energy generation and distribution of electrical power to houses, retail and institutions;	<p>Operation and maintenance phase</p> <p>The project will contribute to improved availability of a sustainable and reliable source of energy which benefits other businesses in the area. Businesses in close proximity to the mini-grid location will therefore benefit from the project. This project will help ensure that more households have access to sustainable energy. Access to energy will therefore enable individual and communities to engage in income generating activities that would otherwise require reliable energy.</p>	Medium [48]

Security of power supply	Positive	Distribution of electrical power to houses, retail and institutions.	<p>Operation phase</p> <p>Conventional sources of energy currently used by the potential beneficiary communities are less secure. Connection to the grids however presents an opportunity to have a safer and reliable energy source.</p>	Medium [36]
Women empowerment and gender integration	Positive	Recruitment and access to electrical power	<p>Construction phase</p> <p>The hiring of women to conduct various roles in the different project stages empowers them. The efforts to provide equal opportunities to both the male and female genders empower women to be more involved in societal activities.</p>	Low [24]
			<p>Operation and maintenance phase</p> <p>The ability to connect to the grid enables women to be more in touch with current affairs and issues affecting them.</p>	Low [18]
Improvement in the standards of living	Positive	Employment creation	<p>Construction Phase</p> <p>Creation of jobs improves people’s livelihoods as they will have increased disposable income. Both men and women will be employed hence there will be gender integration.</p>	Medium [45]
		Distribution of electrical power to houses, retail and institutions.	<p>Operation and maintenance phase</p> <p>Conventional energy sources that are not environmentally and financially sustainable are replaced by a more efficient energy sources. Electricity supply comes with affordable tariffs in relation to present expenditures on energy sources such as paraffin, gas or fuel used for generators.</p>	Medium [36]

			<p>Ability to connect to an electricity grid allows for an increase in the opportunities since individuals have access to information using televisions, laptops, internet among others.</p> <p>Connection to electricity provides the community with an opportunity to extend their working and study hours. Some will either work, study or have meetings during night-hours as well.</p>	
Increased demand for local business/informal traders	Positive	Distribution of electrical power to houses, retail and institutions;	<p>Construction phase</p> <p>There will be increased demand for ready to eat foods, beverages and other services during the construction phase. Growth of local businesses will therefore occur in turn improving living standards for more people such as those of informal traders and their families. There will also be improved economy and lifestyles of the informal traders as a result of improved trading conditions.</p>	Low [24]
			<p>Operation and maintenance phase</p> <p>Availability of a reliable source of energy in the project location attracts more business. Electrical power will increase the ease of doing business therefore traders will be varied ranging from food vendors, printing services, fuels stations, hardware shops, home industries among other businesses.</p>	Low [18]
Economic growth	Positive	Distribution of electrical power to houses, retail and institutions;	<p>Construction phase</p> <p>The project could also influence the economic growth in the project areas in several ways. Payment of taxes and reduction of unemployment through more deliberate employment of locals will aid in the growth of the economy. In addition, the Contractor will also purchase equipment needed as and when practicable.</p>	Medium [36]

			<p>Operation and maintenance phase</p> <p>The project has the potential of attracting more investors thus diversifying the nature of businesses conducted therein. Access to a reliable energy source improves the ease of doing business. Payment of taxes also boosts growth of the economy.</p>	Low [22]
--	--	--	---	----------

4.2.3 HEALTH AND SAFETY RISK AND IMPACTS

Table 4- 3: Description of potential health and safety risks and impacts for different phases of the project

IMPACT	STATUS	ACTIVITY	DESCRIPTION	SIGNIFIANCE PRE- MITIGATION
OCCUPATIONAL /PUBLIC HEALTH AND SAFETY RELATED IMPACTS				
Occupational health and safety incidences	Negative	All construction activities	<p>Pre-construction on and Construction phase</p> <p>Several occupational health and safety risks that could cause injuries or fatalities exist during the construction phase. Some may include injuries from handling machinery and tools onsite leading to cuts, trips, falls, and electrocution among other injuries. In addition, workers may be exposed to risk factors such as hazardous substances which can be injurious to their health either in the short or long term. The general public may also be exposed to health and safety risks especially where they are exposed to haphazardly disposed sharps, chemicals, pollution etc.</p>	Medium [40]
		Operation and maintenance activities.	<p>Operation and maintenance phase</p> <p>The human resources present onsite may be exposed to several occupational risks. During the operational phase the magnitude of these risks increases as the workers conduct maintenance activities</p>	Very low [15]
		Demolition activities and civil works	<p>Closure phase</p> <p>The demolition works conducted, equipment, materials and processes in the</p>	Low [24]

IMPACT	STATUS	ACTIVITY	DESCRIPTION	SIGNIFIANCE PRE- MITIGATION
			decommissioning phase are associated with multiple OSH risks. These risks could result from accidents, fire hazards, sharp objects or inhalation of intoxicants.	
Onset of non-communicable disease and spread of communicable diseases	Negative	Community health	<p>Construction phase</p> <p>Nickel-Cadmium & Lead-acid batteries are partially composed of heavy metals, exposure to which can lead to headaches, brain and kidney damage, abdominal discomfort affect children’s growth, cause sleep problems and in severe cases lead to comas.</p> <p>Absence of proper sanitation facilities could lead to improper sewage disposal and open defecation which can lead to water pollution outbreaks of diarrhoeal diseases and COVID-19. HIV/AIDS and other STDs could spread through the communities in the project site as a result of the influx of migrant labour. Migrant workers may get into sexual relationships outside their marriages with locals thereby increasing the likelihood of the spread of HIV/AIDS infections. Where pools of water and indiscriminate waste dumps exist on site, these can be perfect breeding grounds for several vermin and vectors. Such vectors may spread diseases to local population some of which they may not be immune to.</p>	Low [21]
Increased fire risk	Negative	Smoking; Burning of waste; Making fire to warm up during construction;	<p>Construction phase</p> <p>There are a number of fire risks presented at a construction site including smoking close to flammable objects as well as workers making fire to warm themselves.</p>	Low [18]
			<p>Operation and maintenance phase</p> <p>Fire explosions may be as a result of trees falling on distribution network cables,</p>	Medium [44]

IMPACT	STATUS	ACTIVITY	DESCRIPTION	SIGNIFIANCE PRE- MITIGATION
		Electrification Use of faulty appliances Electrical transmission and use	consequence of improperly stored/handled fuel and/ or overheating of battery banks among other causes; Electrification activities present risks of fires which may be a result of use of faulty electrical equipment or unsuitable electrical apparatus	
Public safety	Negative	Construction activities that involve public interactions such as driving in public.	<p>Construction phase/ Operational and maintenance phase</p> <p>A range of risks with an impact on community health and safety exist.</p> <p>With regards to safety, risks may arise from trucks and machinery (carrying construction material) to the project site disregarding speed limits and other site instructions. Other potential risks include dust which may extend to as far as surrounding communities during the earthworks and excavation and affect community members thereby putting them at a risk of illnesses associated with breathing problems especially people who already have asthma and other obstructive lung diseases.</p>	Low [30]

4.3 PROPOSED MITIGATION MEASURES

Table 4- 4 to Table 4- 6 provide the description of potential environmental, social and health and safety mitigation measures as well as their significance ratings for all project phases.

4.3.1 ENVIRONMENTAL MITIGATION MEASURES

Table 4- 4: Environmental Mitigation Measures

IMPACT	MITIGATION/ENHANCEMENT MEASURES	RESPONSIBLE ENTITY	COST ESTIMATE FOR MITIGATION	SIGNIFICANCE POST MITIGATION
Land clearance and campsite establishment	<ul style="list-style-type: none"> Vegetation removal will be limited to only to areas where removal thereof is necessary. Medicinal plants and endangered species that will be identified in the subproject location will be rescued to a conservation area that shall be approved of by the CLO and ESS in consultation with the local authority and community leaders; No chemical vegetation control shall be utilized during clearing; Areas occupied by topsoil stockpiles shall be re-vegetated using indigenous vegetation growing in the area; Erosion control gabions and structures should be used to prevent soil erosion; Revegetation around the PV plant to achieve ground cover sufficient to control erosion without shading the panels. Low growing grasses which are easy to maintain and will not pose a fire risk should be planted; Disposal of spoil should be done at a site approved by LREEAP ESS and/or CLO and local authorities except in cases where local authorities may 	Contractor	US\$ 1355.30/month for engaging SHE Officer (Total = US\$ 16 263.53) Project costs (included in the preliminary costs)	Low [30]

	<p>request the spoil for land reclamation purposes;</p> <ul style="list-style-type: none"> • Spoil awaiting collection should be barricaded; • The placement of the construction camp must be negotiated with the local authorities, land owners, and the LREEAP ESS and CLO; • The planning and design of the construction camp must ensure that there is a minimum impact on the environment and surrounding communities and that environmental processes (e.g. waste sorting, storage and removal) are well thought out; • No permanent structures will be permitted on site, all buildings on site shall be founded on a platform such as screed slab which will then be removed from site during decommissioning, unless the Developer and the community agree otherwise; • All temporary structures will be soundly built and will not pose any danger to personnel; • Construction camp should be fenced. The purpose of the fence is to control personnel activities within the designated areas, and to contain construction camp activities and prevent trespassing by community members or livestock; • The Contractor must supply cooking facilities for the personnel to be housed at the construction camp; • Fire shall only be made at designated areas. Workers should ensure that fires are completely put off with water or sand or other measures. 			
<p>Exacerbated soil erosion</p>	<ul style="list-style-type: none"> • Minimize vegetation clearing and implement controls for landscape reclamation and soil erosion control by backfilling of erosion channels and restoring subproject site to its proper conditions; • Installation of temporary drainage works during construction works as well as permanent drainage structures for the operation phase; 	<p>Contractor</p>	<p>Project cost (included in the preliminary and general costs)</p>	<p>Medium [40]</p>

	<ul style="list-style-type: none"> • As little topsoil as possible should be removed whilst clearing vegetation within the construction areas; • Ensure that no stockpiling of spoil (excess soil) is performed all over the area during site clearing; • Excavated areas should be backfilled and properly compacted to avoid soil erosion; • Avoid use of invasive species like <i>Pennisetum clandestinum</i> (kikiyu grass/mohloa-tšepe) for re-vegetation of affected areas, where a goal is to establish diverse, resilient native ecosystems; • Vulnerability of the soil to erosion should be determined for the area allocated for the solar PV plant so that necessary measures are included in erosion control plan. 			
<p>Visual impact or loss of environmental aesthetics</p>	<ul style="list-style-type: none"> • Spoil/Rubble Management will be done at the campsite and project site. Disposal of spoil should be done at a site approved by LREEAP ESS and local authorities except in cases where local authorities may request the spoil for land reclamation purposes; • Spoil awaiting collection will be barricaded; • Vegetation will be allowed to naturally re-establish in the areas where it was cleared for the project. 	<p>Contractor</p>	<p>Project cost (where transportation of rubble to approved sites is done, costs will be included in the preliminary and general costs)</p>	<p>Low [25]</p>

<p>Soil and water pollution</p>	<ul style="list-style-type: none"> Measures to prevent products such as lubricants, oil and fuel spillages ensuring that they're properly stored in their designated storage areas; A spill response procedure should be prepared and displayed for use in case of spillages occurring. Spill kits should also be provided; Mobile toilets should be emptied to designated areas approved by LREEAP ESS and local authorities as required, sufficiently cleaned, with no leakages and protected from vandals. Where mobile toilets will not be provided, arrangements should be made with the residents for workers working outside the camp to use their toilets; Constructed toilets should be a minimum of 20m from the water source; Wastewater should be managed at source. This will be achieved through water conservation and recycling as far as reasonably possible; Timely collection and treatment of wastewater will be done; Disposal of wastewater and effluent at the nearest wastewater treatment plant or at authorised disposal sites following conduction of the necessary pre-treatment; Adherence to the regulations for wastewater and influent disposal including standards for each pollutant contained in the effluent disposed of in to the receiving environment. 	<p>Contractor</p>	<p>Project cost (included in the preliminary and general costs)</p>	<p>Low [30]</p>
<p>Waste management</p>	<ul style="list-style-type: none"> A functional waste management plan covering both solid and liquid waste as well as e-waste should be drawn up that provides for the safe collection, storage, transportation and disposal of waste; All work sites must be kept free of construction waste and litter; All waste shall be sorted at source and kept on site within an access-controlled central waste area until disposal; 	<p>Contractor; Community Liaison Officer</p>	<p>US\$ 211.76 once off purchase of bins US\$ 68.00 per month for transportation of</p>	<p>Low [24]</p>

	<ul style="list-style-type: none"> • The sub-project shall investigate ways of minimizing waste generated on site and put these into practice; • All waste that can be recycled (e.g. paper, glass, tin, cement bags, wood, cardboard etc) should be reused; • Hazardous waste including e-waste must be disposed in line with National and international laws and disposal procedures. Management strategies should ensure that hazardous waste generation including e-waste is reduced. The aspects of waste electrical and electronic equipment should be considered in the waste management strategies for the construction as well as operation and maintenance phases of the project. Recycling of such waste thereof should be employed as far as reasonably practicable. Where neither reduction in generation nor recycling is practicable, disposal should be done according to manufacturer guidelines; • Provision of waste bins with lids and clearly labelled for different types of waste. Burning or burying of litter on site is prohibited and a suitable location for disposal of such solid waste should be identified, in consultation with local authorities; • The Contractor shall dispose of all refuse generated by his staff and sub-contractors on a weekly basis at an approved disposal site; • The Contractor shall on a daily basis do site clean-ups of litter other than construction spoil and dispose of it in designated refuse bins provided for on-site. 		<p>waste to disposal sites. (Total = US\$ 813.18)</p> <p>US\$ 275.30 for signage</p>	
<p>Air pollution</p>	<ul style="list-style-type: none"> • Regularly suppress dust on bare areas especially access roads; • Water should be sprayed during loading of rubble onto trucks for transportation to dumping sites; • A dust monitoring register shall be kept; • Water shall be legally abstracted from rivers or any other water 	<p>Contractor</p>	<p>Project cost</p> <p>A water use permit will need to be obtained at a cost of US\$ 267.38</p>	<p>Very low [15]</p>

	<p>resources. The Contractor shall hold a valid water use permit for this abstraction and use;</p> <ul style="list-style-type: none"> • Where possible, dust nets should be placed around the fence or areas of high dust generation during excavations; • Dust masks should be provided to workers; • Dust buckets to be used to monitor dust areas of high dust generation areas during construction. 			
Noise pollution	<ul style="list-style-type: none"> • Control measures should be put for measuring the sound levels and ensuring that they fall within the allowed limits of exposure. That is noise levels should not exceed 70 dB (A) during daytime hours (0700 to 2200hrs) in industrial/ commercial receptors and 55 dB (A) at night time (2200 to 0700hrs) for residential or institutional receptors. Measurement of noise levels can be done using sound level meters and noise dosimeters. A noise monitoring register shall be kept; • Noise from construction activities will be restricted to the schedule agreed in the permit, that is standard working hours will be adopted and strictly adhered to; • During operation, the engine covers of generators, air compressors and other mechanical equipment shall be closed and the equipment will be placed as far as possible from any residential area; • Silencers should be installed on equipment where possible. 	Contractor	<p>Project cost</p> <p>At a once off cost of US\$ 500.00/ unit for procurement of a sound level meter</p>	Very low [15]
Generation and exposure of hazardous waste oils/ chemicals	<ul style="list-style-type: none"> • Hazardous chemicals/ oils shall be stored in a hazardous substances store, which is clearly labelled as such, access controlled, bunded and protected from the elements; • Hazardous chemicals shall be handled by authorized personnel who are qualified to do so; • Any petroleum products awaiting use shall be appropriately stored; 	Contractor	<p>US\$ 211.76 once off purchase of bins</p> <p>US\$ 1,336.90 for once off installation of</p>	Low [24]

	<ul style="list-style-type: none"> Waste petroleum products shall be collected, safely stored on site in a bunded area that is access-controlled and transported to certified waste oil collection companies. Disposal of the waste petroleum products and other hazardous waste should be at appropriate disposal sites. 		<p>bunding in the areas designated for storage hazardous waste oils/chemicals and fuel.</p> <p>US\$ 68.00 per month for transportation of waste to disposal sites. (Total = US\$ 813.18)</p> <p>US\$ 275.30 for signage</p>	
<p>Natural risks/disasters</p>	<ul style="list-style-type: none"> Works should not continue during heavy rainfall; Develop emergency planning procedures to manage the impacts of extreme events related to weather elements and climate change, and ensure existence of emergency vehicle, and provide emergency numbers at the project site. Arrangements can be made to have a vehicle dedicated for use in the event of the occurrence of an emergency. 	<p>Contractor; Developer</p>	<p>Project cost</p>	

<p>Avian collision and electrocution</p>	<ul style="list-style-type: none"> • Characterize the site in terms of bird diversity and abundance, through the use of walked transects and/or point counts of bird species; • Determine where these species occur in the subproject site; • Characterize the site in terms of bird flight behavior over and close to project site; • Avian characterization and determination of species can be done with the help of two locals and engagement of an avifauna specialist in certain instances. This will help in aligning transmission corridors to avoid critical habitats (e.g. nesting grounds, bird foraging corridors, and migration corridors); • Installing visibility enhancement objects such as marker balls, bird deterrents, or diverters. 	<p>Contractor</p>	<p>US\$ 320.86/day for engaging avifauna specialist</p> <p>Total = US\$ 3,208.56 (for ten days engagement)</p> <p>US\$ 10.70/day for engaging local Total = US\$ 213.9 (engagement of two locals for ten days)</p>	<p>Low [30]</p>
<p>Environmental conservation</p>	<ul style="list-style-type: none"> • Adjustment of panels to ensure that efficient sunlight absorption occurs during the peak daylight hours; • Increasing energy efficiency through use of monocrystalline cells; • Use of panels with an antireflective coating to increase cell efficiency; • Recycling of recyclable materials and equipment such as panels, metals, etc. 	<p>Developer; Contractor</p>	<p>Project cost (cost of panels and other hardware)</p>	<p>Medium [52]</p>

4.3.2 SOCIO-ECOCOMIC MITIGATION MEASURES

Table 4- 5: Socio-economic Mitigation Measures

IMPACT	MITIGATION/ENHANCEMENT MEASURES	RESPONSIBLE ENTITY	COST ESTIMATE FOR MITIGATION	SIGNIFICANCE POST MITIGATION
Loss of livelihoods/ property/ land/ relocation of community utilities	<ul style="list-style-type: none"> Site specific Abbreviated Resettlement Action Planning (ARAP) to be prepared in order to address the land acquisition related impacts; Residents shall be informed well in advance of the project intentions and adequate compensation at market rates shall be made for any losses brought about by the project; Continuous community liaison will be made with the affected communities and /or communities in the subproject areas. 	Contractor; Local authorities; PAP; Community Liaison Officer.	Project cost (Development of ARAP and costs for compensation) CLO salary	Medium [32]
Employment creation and skills development	<ul style="list-style-type: none"> Equal employment opportunities should be presented to both the males and females; Employ unskilled and semi-skilled labour from neighbouring communities; Recruitment should also be done in consultation with community leaders and the local authority; Rotation should be done to ensure fairness in the recruitment of unskilled workers. 	Contractor; Local authorities.	US\$ 1,016.50/month for CLO (Total= US\$ 12,197.65)	High [65]
Skills development	<ul style="list-style-type: none"> Developing skills through on-the-job trainings for community workers; Provision of regular trainings for staff. 	Contractor		Medium [36]
Influx of job seekers	<ul style="list-style-type: none"> Contractors should seek to recruit locals for semi-skilled and unskilled labour; Development of a detailed and site-specific labour influx management plan; 	Contractor; Local authorities.	No anticipated costs	Low [27]

	<ul style="list-style-type: none"> • Consultation with local authorities when recruiting. 			
Trafficking in persons (TIP)	<ul style="list-style-type: none"> • Awareness campaigns for trafficking in persons to be conducted thrice a year with the help of the police, CLO and other project supervisors; • Placing TIP awareness posters in different areas within the community; • Clear recruitment procedures and engagement of local authorities during recruitment to prevent deception of jobseekers. 	Contractor	<p>US\$ 267.38 for the awareness training and TIP posters conducted thrice a year.</p> <p>Total = US\$ 802.14</p>	Low [16]
Social exclusion: Inability to connect to the mini-grid	<ul style="list-style-type: none"> • Subsidizing the tariffs and connection fees to accommodate poor households within the different communities. 	Developer	Project cost (Developer's decision based on the availability of funds)	Medium [48]
HIV/AIDS, GBV AND SEA/SH	<ul style="list-style-type: none"> • Recruitment should as far as reasonably possible be sourced locally so that people reside in their own homes where they are less likely to engage in sexual activities outside of their homes; • Identify capacity building opportunities where feasible to support the local communities' activities. This can be achieved by capacity building of GBV actors, on GBV preparedness and response, and GBV risk mitigation and response; • Development of and compliance with a Code of Conduct in relation to prevention of SEA/SH which will be explained to and signed by every employee upon engagement; • There will be continuous awareness raising on sexual exploitation and GBV in Project areas by the community liaison officer to mitigate potential risks of Gender Based Violence (GBV), and Sexual Exploitation 	Contractor	<p>US\$ 2,117.65 three times during the project</p> <p>Total= (US\$ 6,352.90)</p>	Medium [48]

	Abuse or Sexual Harassment during the construction activities.			
Impact on Physical Archaeological and areas of cultural significance	<ul style="list-style-type: none"> Implement Chance Finds Procedure for items of archaeological importance; Identification of alternative routes for distribution lines; Consult with community leaders (i.e. village chief and community council) before construction starts (ideally, during design phase) on the possible types of heritage sites and cultural material in the project area in order for selection of alternative routes. 	Contractor/Developer	Project costs (will depend on chance finds)	Low [22]
Conflicts and project grievances	<ul style="list-style-type: none"> Continuous community liaison throughout the different project phases such that potential causes of conflicts are dealt with; A code of conduct should be provided by Contractor for their workforce; Unskilled labour and semiskilled labour should be sourced from the local communities as far as reasonably practicable; Where foreign or migrant workers will be involved in any of the project phases, integration strategies covering orientation and acclimatization should be designed and implemented to minimize potential tensions and/or risks which shall incorporate the following: <ul style="list-style-type: none"> To aid with the acclimatizing to the community context, language and cultural sensitivity training should be done as well as promoting cross cultural interactions among the workers. In addition, the foreign workers should also be provided with resources and support regarding immigration services, local services and assistance with housing. The integration strategies will ensure smooth transitions and enhance the well-being of workers while deterring possibility of onset of conflicts between locals and foreigners; Provision of public health support for workers such as provision of facilities for good hygiene and encouraging health 	Contractor	CLO's salary US\$ 1,016.50 for GRM implementation	Medium [48]

	<p>lifestyles;</p> <ul style="list-style-type: none"> • Implementation of and awareness raising on project Grievance Redress Mechanism (GRM), including installation of grievance boxes, and establishment of grievance redress community; • The public should be clearly informed of operation procedures including recruitment procedures; • Community access and households’ accesses shall be maintained at all times; • Rotation among the unskilled labourers should also be done to ensure fairness in recruitment, and increased employment opportunities; • Minimising the risk factors for nuisances in the sub-project communities. 			
Theft/ vandalism	<ul style="list-style-type: none"> • Provision of security services. Three security personnel can be engaged and cameras can also be used around the plant; • Educating the community on proper care of the hardware; • Fostering a sense of ownership of the project among villagers in the mini-grid site. 	Developer	<p>[US\$.737.52/month for engaging three security guards</p> <p>Total = 8,850.27 (for the first year of construction)]</p>	Low [21]
Community health and safety: Improved health and safety	<ul style="list-style-type: none"> • Powerline and system maintenance to ensure reliable, and safe energy supply; • Where possible health service centres should be connected to dedicated lines to ensure uninterrupted electricity supply. 	Contractor/Developer	Project Cost	Low [30]

Security of power supply	<ul style="list-style-type: none"> Timely maintenance to ensure reliable energy supply; Ensuring uninterrupted supply of power to the villages and increasing coverage of electrical connections within the communities. 	Local authorities; Developer	No anticipated costs	Medium [36]
Women empowerment and gender integration	<ul style="list-style-type: none"> Social safeguarding to ensure gender is mainstreamed throughout the project design. 	Contractor/Developer.	No anticipated costs	Medium [32]
Improved accessibility to reliable source of energy	<ul style="list-style-type: none"> Timely maintenance to ensure reliable energy supply; Increased access to electricity; Compliance with the Lesotho Electricity and Water Authority (LEWA) electricity tariffs for usage of solar mini-grid electricity, as per the acquired license. 	Developer	Project costs	High [64]
Improvement in the standards of living and livelihoods	<ul style="list-style-type: none"> Recruitment of locals as far as reasonably possible; Timely maintenance to ensure continued and reliable supply of energy. 	Contractor; Developer.	No anticipated costs	High [64]
Increased demand for local business/informal traders	<ul style="list-style-type: none"> Creating an environment that allows small businesses to thrive, through provision of reliable and affordable clean electricity. 	Contractor; Developer.	No anticipated costs	Medium [32]
Economic growth	<ul style="list-style-type: none"> Procurement of Lesotho registered companies as subcontractors as far as reasonably practicable; Payment of taxes according to the Lesotho laws; Any equipment and materials that are locally available and required for 	Contractor; Lesotho Revenue Authority	No anticipated costs	Medium [40]

**ENVIRONMENTAL AND SOCIAL MANAGEMENT PLAN FOR HA NKAU
SOLAR MINI GRID**

2024

	project activities will be sourced locally.			
--	---	--	--	--

4.3.3 HEALTH AND SAFETY MITIGATION MEASURES

Table 4- 6: Health and Safety Mitigation Measures

IMPACT	MITIGATION/ENHANCEMENT MEASURES	RESPONSIBLE ENTITY	COST ESTIMATE FOR MITIGATION	SIGNIFICANCE POST MITIGATION
<p>Occupational health and safety incidences</p>	<ul style="list-style-type: none"> • Appointment of a SHE Officer and representatives; • The Contractor shall compile method statements that detail procedures for activities that are risky to both the environment and employees. These will be included in the Health and Safety plans for the mini-grid to be constructed; • Development of Health and Safety Plan inclusive of baseline risk assessment, fall protection plan as well as other safe work procedures; • Establishment of safety rules at the construction site and application of instructions and rules of hygiene; • Conduct emergency drills at least once a month; • There shall be a trained First Aider and fully-equipped First Aid Kit on site at all times; • All staff shall be made aware of procedures to be followed in case of an accident or emergency and contact details of the nearest emergency unit shall be displayed at strategic locations throughout the construction site; • Adequate PPE/C provision; 	<p>Contractor</p>	<p>Implementation of Health and Safety Plan including provision of appropriate PPE and trainings to be included in the project cost.</p> <p>US\$ 80.21/ person for first aid training</p> <p>US\$ 427.81 for signage</p>	<p>Very low [14]</p>

IMPACT	MITIGATION/ENHANCEMENT MEASURES	RESPONSIBLE ENTITY	COST ESTIMATE FOR MITIGATION	SIGNIFICANCE POST MITIGATION
	<ul style="list-style-type: none"> • Ensure proper staff management; • Warning signs for places at risk; • Ensure provision of safe drinking water and adequate (1 toilet to 20 male workers and 1 toilet to 15 female workers) ablution facilities for workers; • Development of fall protection plan to minimize the risks falling while working at heights; • Development of safe work procedures for working with live electricity including lockout/tag-out procedures; • Limit public access to the construction site as far as reasonably possible; • Allow only qualified electricians to work on electricity connections. 			
<p>Onset of non-communicable disease and spread of communicable diseases</p>	<ul style="list-style-type: none"> • Provision of adequate sanitation facilities for the Contractor’s workforce, as well as the inspectors; • A minimum of one toilet shall be provided for every 20 males, and 15 females. The toilets shall be easily accessible, of neat construction, provided with doors and locks, labeled appropriately, and shall be secured to prevent them from tipping over; • Female toilet shall be equipped with sanitary bins; • Toilets should be positioned close to site so that they are used and that crossing busy roads are 	<p>Contractor; Local authorities; Ministry of health.</p>	<p>Project Cost (to be included in the preliminary and general costs)</p>	<p>Low [18]</p>

IMPACT	MITIGATION/ENHANCEMENT MEASURES	RESPONSIBLE ENTITY	COST ESTIMATE FOR MITIGATION	SIGNIFICANCE POST MITIGATION
	<p>avoided;</p> <ul style="list-style-type: none"> • Mobile toilets should be emptied as required, sufficiently cleaned, with no leakages and protected from vandals; • Arrangement should be made with the residents for workers working outside the camp to use their toilets; • Awareness raising about public health impacts brought about by labour influx particularly awareness on HIV/AIDS and other STIs should be provided to the workers and locals; free condoms should be provided, and placed at strategy locations such as toilets; • Voluntary HIV testing should be regularly proposed to employees. HIV results are kept confidential, and no discrimination shall be made on the basis of HIV or any health status. HIV testing services can be availed to the workforce after every quarter. 		<p>US\$ 534.76 four times during the project</p> <p>Total= (US\$ 2,139.04)</p>	
<p>Public safety</p>	<ul style="list-style-type: none"> • The public should be notified in advance of the construction works; • The site shall have adequate barricading, with adequate safety signage (in both English and Sesotho) warning the public of safety risks, as well as traffic calming signage; 	<p>Contractor</p>	<p>Project Cost (Barricading costs are included in the preliminary and general costs)</p>	<p>Low [21]</p>

IMPACT	MITIGATION/ENHANCEMENT MEASURES	RESPONSIBLE ENTITY	COST ESTIMATE FOR MITIGATION	SIGNIFICANCE POST MITIGATION
	<ul style="list-style-type: none"> Should flagmen be required to warn road users and the public of moving construction equipment and vehicles two should be employed; Access to the construction site shall be limited as far as reasonably possible; Construction vehicles should adhere to speed limits to avoid accidents. 		US\$ 155.08/month for engaging each flagman Two flagmen will be engaged for a period of 12months Total= (US\$ 3,721.93)	
Fire risks	<ul style="list-style-type: none"> Proper insulation of power cables and periodic or scheduled maintenance of transformers; All necessary measures shall be taken to ensure that fires are not started as a result of construction or any other related activities; Signage shall be posted onsite which prohibits lighting of fires in undesignated areas; Fire shall be contained and not made in windy conditions; Fire shall only be made at designated areas and smoking done in designated areas; Workers shall also ensure that fires are completely put out with water or sand or other measures; The community should be conscientised on the importance of not starting fires close to the distribution lines; Rights of way should be well maintained without 	Contractor; Firefighting	Project Cost (Operational fire extinguishers are included in the preliminary and general costs). US\$ 80.21/ person for fire marshal training Total= US\$ 160.43 (for two fire marshals)	Medium [32]

IMPACT	MITIGATION/ENHANCEMENT MEASURES	RESPONSIBLE ENTITY	COST ESTIMATE FOR MITIGATION	SIGNIFICANCE POST MITIGATION
	<p>burning of vegetation done;</p> <ul style="list-style-type: none"> • Provision of and regular inspection and servicing of basic firefighting equipment on site, including operational fire extinguishers that are mounted, easily accessible and signage indicating their position onsite including Contractor’s camp and at each work front; • Fire Marshal shall be trained on basic firefighting techniques and shall be the first point of contact for any fires detected on site. Two fire marshals will be trained; • All staff shall be made aware of the position of the emergency assembly point in the in the event of a fire and the community sensitized on the know-how of electricity; • All staff shall be made aware of procedures to be followed during a fire and mock fire drills shall be conducted on monthly basis; • Contact details of the nearest fire station shall be displayed at strategic locations throughout the construction site; • The height of vegetation below solar panels should be kept low to prevent fire risks. 			

IMPACT SIGNIFICANCE LEGEND

Rating	Description	Color code
4-15	Very low	Green
16-30	Low	Yellow
31-60	Medium	Orange
61-80	High	Red
81-100	Very high	Purple

5 ESMP MONITORING AND REPORTING

5.1 MONITORING AND REPORTING OBJECTIVES

Monitoring and reporting forms an integral part of the ESMP in order to ensure that management measures are effectively implemented. Monitoring objectives are therefore:

- Provide a database from which the environmental and social risks and impacts of the project can be assessed;
- Provide an early indication should any of the environmental and social controls or practices fail to achieve the acceptable standards;
- Monitor the performance of the sub-project and effectiveness of the mitigation measures;
- Determine sub-project compliance with regulatory requirements, standards; and
- Guide remedial actions if unexpected problems or unacceptable impacts arise.

5.2 MONITORING AND EVALUATION INDICATORS

This section, as presented in table 5-1 provides environmental, social and health and safety indicators which will show when milestones have been achieved at the mini-grid site.

Table 5- 1: Environmental, social, health and safety management monitoring indicators

Measure	Category	Indicator (*)
Monitoring	Environmental monitoring and control of the sub-project.	Number of inspections and audits completed to monitor risks and impacts mitigation measures.
Sensitization	Raising public awareness and advocacy on the environmental, health, safety and social issues of sub-projects and good practices; Key stakeholder consultation and engagement.	Number of people who benefited from these sessions (with percentage of women indicated); Key stakeholder engagements sessions are conducted before the commencement of the sub-project.

Measure	Category	Indicator (*)
Grievance management	Management of grievances of parties directly or indirectly affected by Project activities.	<p>Number of grievances received;</p> <p>Number of grievances resolved including those related to GBV and SEA/SH;</p> <p>The main Contractor and all sub-contractors staff are trained on ESMP requirements and GRM procedures;</p> <p>All grievances raised are dealt with timeously.</p>
OHS related Management	Ensuring readiness with engaging competent OHS and safeguards personnel and compliance with other requirements.	<p>Key safeguards and OHS requirements are included in the bid documents;</p> <p>Key indicators for OHS will include number of incidents, number of inspections, number of emergency drill conducted as well as risk assessments in place for all activities etc.</p>
Monitoring environmental measures	Ensuring compliance and adequate reporting.	<p>All mitigation measures in the specifications and Method Statements are implemented accordingly;</p> <p>Monthly and quarterly monitoring reports;</p> <p>End of sub-project E&S Monitoring Reports are made available to relevant parties. Some of the indicators to be covered include number of environmental incidents, number of awareness sessions, MSTs in place prior to conducting activity, number of audits and inspections, number of corrective actions completed within a specified time</p>

5.3 ENVIRONMENTAL AND SOCIAL MANAGEMENT COMPLIANCE MONITORING

Compliance monitoring will ensure that the environmental and social mitigation measures are implemented, and residual impacts are monitored. Therefore, the PIU will provide relevant

support to the Contractor to ensure compliance to the ESMP requirements during the construction phase of the sub-project.

Safety, Health and Environmental monitoring must be done at the mini-grid site in Ha Nkau daily by the Contractor's SHE Officer.

The LREEAP ESS shall be engaged to carry out fortnight or monthly monitoring of the Contractor's compliance to the ESMP during construction phase and produce monthly reports to the PIU, co-signed by the project community liaison officer. During operation and maintenance phase, monitoring and internal audits will be carried out by the respective relevant authorities.

Table 5-2 presents the mitigation measures that the Developer has to implement in order to manage the identified potential impacts for all the phases of the project. It also provides the monitoring plan to ensure that mitigation measures are properly implemented.

In terms of monitoring costs, monitoring shall be done by LREEAP staff (LREEAP-CLO and LREEAP-ESS), Contractor's Engineer, Contractor's SHE officer and GRC and their remuneration shall form part of project costs.

Table 5- 2 : Environmental Management and Monitoring Plan of identified potential impacts

IMPACT	SUMMARY OF MITIGATION OR ENHANCEMENT MEASURES ¹⁰	TIME OF ACTION	PERFORMANCE INDICATOR	CAPACITY BUILDING REQUIRED	MONITORING FREQUENCY	MONITORING ORGANISATION
ENVIRONMENTAL/BIOPHYSICAL MITIGATION MONITORING						
Site clearance and campsite establishment	<ul style="list-style-type: none"> Limit vegetation removal and rescue of endangered plant species; Soil erosion control measures; Spoil management measures; Placement and design of construction camp with minimal impacts. 	Preconstruction phase and construction phase	<ul style="list-style-type: none"> No areas left bare; Topsoil stored and protected from erosion. 	-	Monthly	LREEAP-CLO, LREEAP –ESS.
Exacerbated soil erosion	<ul style="list-style-type: none"> Soil erosion control and rehabilitation measures. 	Preconstruction and construction phase	<ul style="list-style-type: none"> Soil erosion control plan developed; No areas left bare; Topsoil stored and protected from erosion. 	Sensitization of Contractor workers.	Monthly	LREEAP- CLO, LREEAP- ESS.

¹⁰ Detailed mitigation measures provided in section 4.3 – proposed mitigation measures

IMPACT	SUMMARY OF MITIGATION OR ENHANCEMENT MEASURES ¹⁰	TIME OF ACTION	PERFORMANCE INDICATOR	CAPACITY BUILDING REQUIRED	MONITORING FREQUENCY	MONITORING ORGANISATION
Visual impact or loss of environmental aesthetics	<ul style="list-style-type: none"> • Spoil/Rubble management measures; • Re-vegetation and implementation of other rehabilitation measures. 	Preconstruction, construction and close phases	<ul style="list-style-type: none"> • Maintenance of environmental aesthetics. 	Sensitization of Contractor workers.	Monthly	LREEAP-CLO, LREEAP –ESS.
Soil and water pollution	<ul style="list-style-type: none"> • Spill prevention and response measures; • Provision and maintenance of sanitation facilities; • Appropriate waste management measures; • Adherence to the regulations for wastewater and influent disposal including standards for each pollutant contained in the effluent disposed of in to the receiving 	Construction, operation and closure phase	<ul style="list-style-type: none"> • Spill prevention and response plan in place; • No oil spillages at construction site and at points along the distribution line; • No harm caused on human health and the receiving environment; • Adherence to standards. 	Sensitization of Contractor workers.	Weekly	LREEAP-CLO, LREEAP-ESS.

IMPACT	SUMMARY OF MITIGATION OR ENHANCEMENT MEASURES ¹⁰	TIME OF ACTION	PERFORMANCE INDICATOR	CAPACITY BUILDING REQUIRED	MONITORING FREQUENCY	MONITORING ORGANISATION
	environment.					
Solid waste management	<ul style="list-style-type: none"> Development and implementation of a waste management plan. 	Construction, operation and closure phase	<ul style="list-style-type: none"> Presence of waste management plan and records of its implementation. 	Sensitization of Contractor workers.	Weekly	LREEAP-CLO, LREEAP-ESS.
Air pollution	<ul style="list-style-type: none"> Dust suppression and monitoring measures; Maintenance of plant to minimise emissions. 	Preconstruction, construction and closure phase	<ul style="list-style-type: none"> Low dust levels; Records of dust suppression and monitoring; Dust levels within acceptable WHO standards; No community complaints on dust levels. 	Sensitization of Contractor workers.	Weekly	LREEAP-CLO, LREEAP-ESS.
Noise pollution	<ul style="list-style-type: none"> Noise minimisation and monitoring measures. 	Construction and operation phase, closure phase	<ul style="list-style-type: none"> Records of noise monitoring; No community complaints in relation to dust and noise. 	Sensitization of Contractor workers; Purchasing of sound level meters.	Weekly	LREEAP-CLO, LREEAP-ESS.

IMPACT	SUMMARY OF MITIGATION OR ENHANCEMENT MEASURES ¹⁰	TIME OF ACTION	PERFORMANCE INDICATOR	CAPACITY BUILDING REQUIRED	MONITORING FREQUENCY	MONITORING ORGANISATION
Generation and exposure of hazardous waste oils/chemicals	<ul style="list-style-type: none"> Minimising exposure to hazardous chemicals in handling, storage and disposal. 	Throughout project line cycle	<ul style="list-style-type: none"> MSDS available on site; Records of safe disposal of hazardous waste. 	Sensitization of Contractor workers.	Weekly	LREEAP-CLO, LREEAP-ESS.
Natural risks/disasters	<ul style="list-style-type: none"> No works during extreme weather conditions; Develop emergency planning procedures to manage the impacts of extreme events related to weather elements and climate change. 	Throughout project lifecycle	<ul style="list-style-type: none"> Emergency management procedures in place. 	Sensitization and Contractor workers.	Quarterly	LREEAP-CLO, LREEAP-ESS.
Avian collision and electrocution	<ul style="list-style-type: none"> Minimising the impact of the project on avifauna. 	Operation phase Operation and maintenance phase.	<ul style="list-style-type: none"> Nesting areas of bird species established in the project area to avoid tempering with them; Visibility enhancement objects such as marker balls, bird deterrents, or diverters installed where 	-	Quarterly	LREEAP-CLO, LREEAP-ESS.

IMPACT	SUMMARY OF MITIGATION OR ENHANCEMENT MEASURES ¹⁰	TIME OF ACTION	PERFORMANCE INDICATOR	CAPACITY BUILDING REQUIRED	MONITORING FREQUENCY	MONITORING ORGANISATION
			necessary.			
Environmental conservation	<ul style="list-style-type: none"> Ensuring efficiency of PV plant; Recycling of recyclable materials. 	Operation and maintenance phase; Closure phase.	<ul style="list-style-type: none"> Energy efficiency optimised; Sound e-waste management. 	Sensitising PAP on recycling options for electronic waste and other environmental conservation strategies.	Quarterly	Ministry of Energy.
SOCIO-ECONOMIC MITIGATION MONITORING						
Loss of livelihoods/ property/ land/ relocation of community utilities	<ul style="list-style-type: none"> Resettlement action planning and implementation; Continuous liaison with PAPs. 	Preconstruction and construction phase	<ul style="list-style-type: none"> ARAP prepared; Records of affected assets and compensations. 	Sensitization of communities on compensation procedure.	Monthly	LREEAP-ESS.
Employment creation	<ul style="list-style-type: none"> Transparent recruitment procedures; Rotation of local 	Throughout project lifecycle	<ul style="list-style-type: none"> Records of employed labourers available; No influx of job seekers at the construction site. 	Technical skills development	Monthly	LREEAP-CLO, LREEAP-ESS.

IMPACT	SUMMARY OF MITIGATION OR ENHANCEMENT MEASURES ¹⁰	TIME OF ACTION	PERFORMANCE INDICATOR	CAPACITY BUILDING REQUIRED	MONITORING FREQUENCY	MONITORING ORGANISATION
	unskilled workers.					
Skills development	<ul style="list-style-type: none"> Developing skills through on-the-job trainings for labourers; Provision of regular trainings for staff. 	Throughout project lifecycle	<ul style="list-style-type: none"> Records of trainings for unskilled labour and other personnel. 	On the job training for labourers; Regular training for staff	Monthly	LREEAP-CLO, LREEAP-ESS.
Influx of job seekers	<ul style="list-style-type: none"> Development and implementation of site-specific labour influx management plan. 	Preconstruction and operation phase	<ul style="list-style-type: none"> Skilled and semi-skilled labourers from local authorities engaged. 	-	Monthly	LREEAP ESS.
Trafficking in persons	<ul style="list-style-type: none"> TIP prevention measures such as TIP awareness. 	Construction phase; Operation and maintenance phase.	<ul style="list-style-type: none"> Records of TIP awareness campaigns conducted; No TIP cases. 	Awareness campaigns	Monthly	LREEAP-CLO, LREEAP-ESS.
Social exclusion: Inability to connect to the mini-grid	<ul style="list-style-type: none"> Subsidizing tariffs to accommodate for the poorest households within the different communities. 	Operation phase	<ul style="list-style-type: none"> Regulated and subsidised tariffs. 	Tariffs, and connection procedures.	Quarterly	Ministry of Energy.

IMPACT	SUMMARY OF MITIGATION OR ENHANCEMENT MEASURES ¹⁰	TIME OF ACTION	PERFORMANCE INDICATOR	CAPACITY BUILDING REQUIRED	MONITORING FREQUENCY	MONITORING ORGANISATION
HIV/AIDS, GBV AND SEA/SH	<ul style="list-style-type: none"> HIV/AIDS, GBV AND SEA/SH Action plan/management procedures 	Throughout project lifecycle	<ul style="list-style-type: none"> Code of Conduct in relation to prevention of SEA/SH explained to and signed by every employee upon engagement; Functional GRM. 	Community and workers sensitization on HIV/AIDS, GBV AND SEA/SH.	Monthly	LREEAP-CLO, LREEAP-ESS.
Impact on Physical Archaeological and areas of cultural significance	<ul style="list-style-type: none"> Implementation of Chance Finds Procedure for items of archaeological importance. 	Preconstruction and construction phase	<ul style="list-style-type: none"> Undisturbed archaeological areas including caves and old graves. 	Train workers on chance finds procedures.	Monthly	Local authority, LREEAP-CLO, LREEAP-ESS.
Conflicts and project grievances	<ul style="list-style-type: none"> Implementation of and awareness raising on project Grievance Redress Mechanism (GRM); Minimising risk factors for nuisances in 	Preconstruction, construction and operation phase	<ul style="list-style-type: none"> Percentage of complaints addressed within the specified GRM timeframes; Presence of GM signage (with contact persons and details) box on site. 	Train GR committee on GRM procedures.	Monthly	LREEAP-ESS.

IMPACT	SUMMARY OF MITIGATION OR ENHANCEMENT MEASURES ¹⁰	TIME OF ACTION	PERFORMANCE INDICATOR	CAPACITY BUILDING REQUIRED	MONITORING FREQUENCY	MONITORING ORGANISATION
	communities.					
Theft/ vandalism	<ul style="list-style-type: none"> Provision of security services; Fostering a sense of ownership of the project among villagers in the mini-grid site. 	Construction, operation and closure/rehabilitation phase	<ul style="list-style-type: none"> Security measures in place; Records of community sensitisation. 	Community training on proper care of hardware.	Monthly	LREEAP CLO.
Community health and safety: Improved health and safety	<ul style="list-style-type: none"> Power line and system maintenance to ensure reliable energy supply. 	Operation and maintenance phase	<ul style="list-style-type: none"> Uninterrupted and efficient energy supply. 	Community training on handling of electricity.	Quarterly	Department of Energy.
Improved accessibility to reliable source of energy	<ul style="list-style-type: none"> Power line and system maintenance to ensure reliable energy supply; Compliance with LEWA approved tariffs. 	Operation and maintenance phase	<ul style="list-style-type: none"> Regulated prices per unit. 	Training on connection procedures, and efficient use of electricity.	Quarterly	Department of Energy.

IMPACT	SUMMARY OF MITIGATION OR ENHANCEMENT MEASURES ¹⁰	TIME OF ACTION	PERFORMANCE INDICATOR	CAPACITY BUILDING REQUIRED	MONITORING FREQUENCY	MONITORING ORGANISATION
Improvement in the standards of living and livelihoods	<ul style="list-style-type: none"> Recruitment of locals as far as reasonably possible. 	Throughout project life cycle	<ul style="list-style-type: none"> Reliable power supply. 	Training on efficient use of electricity.	Monthly	LREEAP-CLO, LREEAP-ESS.
OCCUPATIONAL HEALTH AND SAFETY AND PUBLIC SAFETY						
Occupational health and safety incidents	<ul style="list-style-type: none"> Engagement of safety personnel; Development of Health and Safety Plan inclusive of baseline risk assessment, fall protection plan as well as other safe work procedures. 	Throughout project lifecycle	<ul style="list-style-type: none"> Health and safety plan developed and records of implementation in place. Limited or no health and safety incidents; Number of workers trained; PPE/C issue register. 	First aid training; Provision of site induction for new workers, subcontractors and visitors.	Weekly	LREEAP-CLO, LREEAP-ESS.
Onset of non-communicable disease and spread of communicable diseases	<ul style="list-style-type: none"> Provision of sanitation facilities for the Contractor's workforce Awareness raising about public health impacts brought about by labour influx/ 	Throughout project lifecycle	<ul style="list-style-type: none"> Records of training; Conduction of awareness campaigns; No infections. 	Contractor workers awareness training on spread of communicable diseases like	Monthly	LREEAP-CLO, LREEAP-ESS.

IMPACT	SUMMARY OF MITIGATION OR ENHANCEMENT MEASURES ¹⁰	TIME OF ACTION	PERFORMANCE INDICATOR	CAPACITY BUILDING REQUIRED	MONITORING FREQUENCY	MONITORING ORGANISATION
	change in demographics.			HIV/AIDS and COVID-19.		
Public safety	<ul style="list-style-type: none"> Implementation of public safety and traffic safety measures; Awareness of safety in using electrical equipment. 	Throughout project lifecycle	<ul style="list-style-type: none"> Posting of safety signage; Control of access to project site; No occurrence of accidents or onset of health outcomes attributable to the project activities among the PAP. 	Community training on safety precautions towards electrical equipment; Sensitisation on risks associated with project activities.	Quarterly	LREEAP-CLO, LREEAP-ESS.
Fire risks	<ul style="list-style-type: none"> Development and implementation of emergency preparedness and response plan. 	Construction; Operation and maintenance phase.	<ul style="list-style-type: none"> Records of implementation of emergency and response plan e.g drills; Fire prevention plan in place for the operation phase; Firefighting equipment in place. 	Firefighting training.	Quarterly	LREEAP-CLO, LREEAP-ESS.

IMPACT	SUMMARY OF MITIGATION OR ENHANCEMENT MEASURES ¹⁰	TIME OF ACTION	PERFORMANCE INDICATOR	CAPACITY BUILDING REQUIRED	MONITORING FREQUENCY	MONITORING ORGANISATION
Economic growth	<ul style="list-style-type: none"> • Procurement of Lesotho registered companies as subcontractors as far as reasonably practicable. • Payment of taxes according to the Lesotho laws; • Any equipment that is locally available and required for project activities will be sourced locally. 	Throughout project lifecycle	<ul style="list-style-type: none"> • Tax clearance certificate; • Engagement of local Contractors. 	-	Yearly	LREEAP-Procurement Specialist, LREEAP-Finance Specialist.

5.4 ESMP REPORTING

5.4.1 REPORTING BY PIU

The PIU will prepare various reports during the implementation of this ESMP. End of sub-project reports that highlight key compliance issues, based on the Contractor's EHS Officer's reports and the team's observations during the monitoring visits will be prepared. These reports will be shared with all Stakeholders including the World Bank, upon request.

5.4.2 ENVIRONMENT, HEALTH AND SAFETY INCIDENTS

- All incidents should immediately be reported to the supervisors and SHE Officer for corrective actions and investigations;
- All significant incidents should be reported to the Department of Labour as per Labour Code Order of 1992 requirements;
- The cause of all incidents should thoroughly be investigated to prevent recurrences;
- Preventative actions should be in place to prevent future incidents.

Contents of the incident report should amongst others include the following:

- Time, date and nature of the incident;
- Response and investigation undertaken;
- Actions taken and by whom;
- Preventative actions to prevent future occurrences.

The Contractor will ensure that there is an emergency procedure before commencing any operations that may cause damage to the environment or put the health and safety of personnel at risk or lead to undesirable incidents. The Contractor must ensure that all sub-contractors are familiar with all emergency procedures to be followed. The Contractor must ensure the list of all emergency telephone numbers/contact people are kept up to date, and that all numbers and names are posted at relevant locations at all times. In addition, all environmental, health and safety incidents occurring on site must be recorded in an environmental, health and safety incidents report.

5.4.3 RECORD KEEPING

The Contractor shall ensure that a paper filing system identifying all documentation related to the ESMP is established. Below is a list of documents to be kept and utilized during the project:

- Environmental and Social Management Plan;
- Health and Safety Plan;
- Approved Method Statements;
- All communications detailing changes of scope that may have environmental implications;
- Daily, weekly and monthly site monitoring reports;
- Safety, Health and Environmental incidents reports and non-conformance reports;
- Training manual and training attendance registers;
- Emergency preparedness and response plans;
- Permits and legal documents, including letters authorizing specific personnel of their duties as part of emergency preparedness team;
- Induction records;
- Photographic records;
- Gender Based Violence (GBV) Register;
- Grievance Register (logbook);
- Waste management records including disposal records;
- List of “toolbox talks” topics and registers of talks held.
- Records of community gatherings (e.g. minutes, registers, photographic records).

5.4.4 ADAPTIVE MANAGEMENT

The ESMP is a living document and must remain relevant to the sub-project as and when the scope evolves. The requirements contained in this ESMP may thus need to be reviewed and amended to ensure its applicability to the sub-project over the duration of the sub-project. It is recommended that the ESMP is reviewed once a year throughout the construction phase of the sub-project, or as when necessary. This should include the identification of any unforeseen/additional environmental and social risks that may have emerged since the commencement of the sub-project, and development of appropriate mitigation measures to manage such risks and impacts.

6 INSTITUTIONAL ARRANGEMENTS FOR ENVIRONMENTAL AND SOCIAL MANAGEMENT PLAN

The ESMP shall be implemented by the Environmental Management Committee (EMC) supported by the Project Implementation Unit (PIU) that forms part of the EMC (See Figure 6- 1): Institutional Arrangements). The PIU has a dedicated team of national environmental, safety and social personnel to ensure effective and efficient implementation of the ESMP. The Client, Developers/Contractor(s)/subcontractor(s), and the beneficiary communities provide integral support in the ESMP implementation, reporting and other relevant functions. Sections below provide further details in this regard.

The Environmental Management Committee (EMC)

This will be a multidisciplinary team tasked with monitoring and facilitating implementation of the ESMP and will resolve any environmental problems that may arise during the construction phase.

The EMC will be composed of:

- The Client (Environmental and Social Specialist) – Lesotho Renewable Energy and Energy Access Project: Department of Energy (LREEAP – DoE) PIU through the LREEAP ESS and LREEAP CLOs will be responsible for construction supervision;
- Safety, Health and Environment (SHE) Officer - Contractor/Developer responsible for construction or development of the mini grid;
- Community representative.

The Contractor with specific reference to the ESMP shall be responsible for appointing and assigning SHE Officer; ensuring that all sub-contractors appointed by the Contractor are aware of their environmental responsibilities, as well as complying with the ESMP; and providing appropriate resources for ESMP implementation.

The SHE Officer will be responsible for overseeing the Contractor’s compliance to the ESMP and ensuring that the safety, health and environmental specifications are adhered to. The SHE Officer will keep records of all site activities and issues in relation to SHE aspects. The SHE Officer must also ensure safety, health and environmental awareness amongst the Contractor’s employees and sub-contractors.

External audit of Contractor’s compliance with the ESMP shall be carried out by the LREEAP ESS and LREEAP CLOs.

6.1 ROLES AND RESPONSIBILITIES

The implementation of the ESMP is dependent on the involvement and cooperation of a number of key role players. The level of involvement and responsibilities of each of these role players will vary during different stages of the development, but they are all vital to the successful environmental and social management of this project. The organogram in figure 6-1 illustrates role players directly responsible for the implementation of the ESMP.

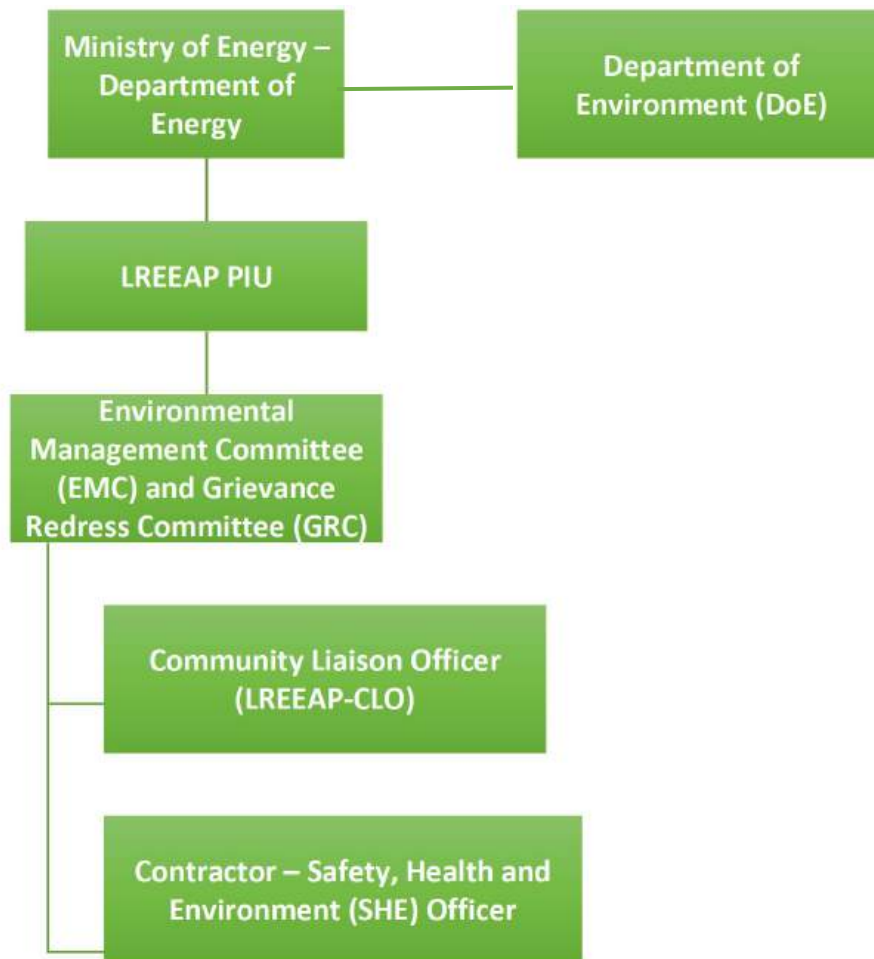

Figure 6- 1: Organogram illustrating the key role players in the project

The Department of Environment as the regulatory body ensures that the project's environmental aspects are managed in accordance with national regulations. Responsibilities include:

- Reviewing and approving the ESMP and issuing record of decision.
- Conducting periodic inspections to ensure compliance with environmental regulations.
- Providing guidance on environmental best practices.
- Overseeing the implementation of mitigation measures to minimize environmental impact.

Ministry of Energy - Department of Energy as the policy maker and overarching authority for the LREEAP project, the Department of Energy holds key responsibilities in the implementation of the Environmental and Social Management Plan (ESMP). The following outlines the relevant responsibilities:

- Ensure that the ESMP aligns with national energy policies and environmental regulations;
- Ensure adequate funding and resources are allocated for the implementation of the ESMP;
- Facilitate coordination between various government agencies and departments to ensure a unified approach to ESMP implementation;
- Facilitate engagement with key stakeholders, including local communities, government entities, and international partners;
- Ensure that stakeholder concerns and inputs are incorporated into the project planning and implementation processes;
- Support the LREEAP PIU (Project Implementation Unit) in addressing high-level issues and challenges related to ESMP implementation.

LREEAP as the implementing unit of this project, must ensure that environmental and social compliance is clearly defined in the bidding documents for the Contractor and is implemented. Responsibilities shall include amongst others:

- Oversee the works and spending to ensure smooth construction activities and will supervise the construction works based on the designs (this is the direct responsibility of LREEAP PIU Mini-grid Manager/Engineer);

- Ensuring that relevant WB environmental and social requirements (including Management Implementation Strategy Plans [MISP] including the Code of Conduct [CoC] (see annexure 11.7) are included in the Environment and Social Health and Safety (ESHS) specifications of the procurement documents and contracts;
- Issuing instructions for corrective actions where there is non-compliance by the Contractor;
- Reviewing and approving of proposed site layout plans, proposals for site infrastructure, pollution prevention measures and construction method statements and Safe Work Procedures produced by the Contractor for environmental compliance;
- Monitoring implementation of the ESMP, and the mitigation measures and management actions contained in the ESMP; and
- Produce end-of-construction ESMP implementation report and submit it to the WB.

LREEAP (Environmental and Social Specialist) ESS – will coordinate the environmental monitoring to ensure compliance of the construction activities to the specifications of the ESMP. The LREEAP ESS shall produce monthly reports to the Client (LREEAP-Ministry Department of Energy) PIU on the progress of implementation of the ESMP by the Contractor and all his sub-contractors.

The Community Liaison Officer (LREEAP-CLO) – is responsible for coordination and communication between the community and the Contractor.

Among others, the CLO shall:

- Coordinate recruitment of local unskilled labourers;
- Coordinate community gatherings;
- Coordinate the grievance redress committee;
- Coordinate Contractor and other stakeholder’s issues;
- Disseminate information to co-workers; and
- Maintains complaints register.

The Contractor – as the undertaker of all the construction related activities must:

- Ensure implementation of the ESMP;
- Develop Management Implementation Strategy Plans (MISPs) including the following:
 - Construction ESMP/Environmental Protection Plan;

- Occupational Health and Safety (OHS) Plan
 - Codes of Conduct to be signed by all employees;
 - Corporate social responsibility plan
 - Sustainable procurement plan;
 - Labour influx management plan;
 - Erosion prevention and control plan;
 - Fire prevention plan incorporating vegetation management (particularly solar PV plant area and surrounds during the operation phase);
 - Waste Management Plan;
- Provide human and financial resources necessary for the implementation of the ESMP;
 - Ensure that environmental specifications of the ESMP and relevant legislative requirements are effectively implemented;
 - Preserve the biophysical and social environment, by limiting any destructive actions by his employees and sub-contractors;
 - Monitor the performance and conformance with specifications contained in the ESMP;
 - Report progress towards implementation of and non-compliance with the ESMP;
 - Keep and avail suitable records and documents to key stakeholders;
 - Report and record all accidents and incidents resulting in injury or death;
 - Timely submission of reports, information, and data;
 - Participation in the meetings convened by the PIU and other authorities; and
 - Any other assistance requested by the PIU/other authorities.

Contractor's Safety, Health and Environment (SHE) Officer – is assigned to ensure that all the Safety, health and environment specifications are adhered to by:

- Prepare and implement EHS method statements and Construction ESMP/Environmental Protection Plan based on the recommendations on management and mitigation measures incorporated in the ESMP;
- Prepare OHS plan;
- Ensure that all sub-contractors appointed by the Contractor are aware of their environmental responsibilities and that they comply with the ESMP;
- Provision of appropriate resources for ESMP implementation and overseeing the internal compliance to the ESMP;

- Inspection of the site;
- Keep records of all site activities and issues in relation to SHE aspects;
- Ensure safety, health and environmental awareness among the Contractor’s employees, sub-contractors and workforce;
- Ensure that the safety, health and environmental specifications are adhered to;
- Ensure safety, health and environmental awareness and training for employees and sub-Contractors;
- Report and record all accidents and incidents occurring on site and analyse them to prevent future occurrence;
- Undertake risk assessments;
- Ensure that workers use their personal protective clothing and equipment such as respirators, overalls, gloves, goggles, safety shoes and ear plugs;
- Ensure that toolbox talks are provided for labourers;
- Advises and reminds foremen about Health and safety issues
- Supervise environment and social related work of the Contractor;
- Monitor dust, noise, waste generation, and other EHS issues; and
- Compile monitoring reports.

The Grievance Redress Committee - This is a committee that will be composed of LREEAP-CLO, Contractor SHE officer and three community members that is, an adult male, adult female and a youth. The key function of this committee will be to resolve project grievances at the sub-project level. As such, it will be established to hear and make decisions on the complaints and grievances made by the affected parties regarding resettlement covering issues to do with land acquisition, asset loss and loss of livelihoods brought about by the project.

6.2 INSTITUTIONAL ARRANGEMENTS

This section (see Table 6- 1, Table 6- 2 and Table 6- 3) describes the roles and responsibilities of each organisation involved in the implementation and monitoring of the ESMP.

Table 6- 1: Implementing Agency

ORGANIZATION	ROLE
LREEAP PIU	The LREEAP PIU under the Department of Energy will have to ensure the development

ORGANIZATION	ROLE
	<p>and overall implementation of the ESMP. PIU safeguards team is also responsible for disclosure of the ESMP. The PIU environmental and social safeguards specialist shall ensure inclusion of ESMP requirements into Developer/Contractor’s procurement/contract documents.</p> <p>In addition, PIU shall provide necessary resources and training and orientation to ensure efficient implementation of the ESMP. The PIU shall be involved in monitoring the implementation of the ESMP during the construction phase as well as reporting on its implementation, assisted by community liaison officers deployed at the mini grid site, to provide daily oversight of the Contractor’s activities and foster engagement with the local communities.</p> <p>The PIU has to ensure that training and awareness on environmental, social, health and safety mitigation actions is provided to Contractor prior to commencement of construction works.</p> <p>The PIU is also tasked with addressing all grievances related to the project, working in collaboration with the project grievance redress committee.</p>

Table 6- 2: Contractor/Developer

ORGANIZATION	ROLE
Contractor/Developer	<p>The Contractor has the responsibility of ensuring the overall compliance with environmental and social management plan throughout the development stages of the mini-grid.</p> <p>The Contractor has to ensure that high quality machinery and equipment is deployed on daily basis, adhering to relevant environmental standards;</p> <p>The Contractor also has to ensure that all employees adhere to the environmental, health and safety requirements during all stages of project implementation. The Contractor shall be responsible for routine reporting on the implementation of the ESMP to the Client.</p>

Table 6- 3: Other Government Departments responsible in implementation of the ESMP

ORGANIZATION	ROLE
Department of Environment (DoEnv)	<p>The Department of Environment is responsible for reviewing and approving the ESMPs.</p> <p>The department also advises on the preparation of Terms of Reference (ToRs) for the required safeguards instruments and arrange for review for such instruments and stakeholder consultations.</p> <p>DoEnv is also responsible for monitoring and enforcing conditions set out in the Record of Decision (RoD) and/or Environmental Clearance issued for the project.</p>
Local Authorities (chiefs and community council)	<p>The local authorities undertake regular monitoring of on-site project activities conducted by the Contractor. Their primary aim is to protect the well-being of communities and their resources as well as assisting in grievances or any conflicts resolutions. In addition, they shall assist in identifying waste disposal areas, and campsite areas, as well as coordinating community gatherings.</p>
Ministry of Finance	<p>The Ministry of Finance monitors the disbursement of funds to ensure the implementation of the ESMP, and ensures compliance with the project financing agreement.</p>

7 TRAINING AND AWARENESS RAISING

7.1 CAPACITY DEVELOPMENT FOR PROJECT WORKERS

This section recommends the capacity needs for role players (i.e. Contractors/Developers, Department of Energy, local authorities, communities, LREEAP-CLOs, and grievance redress committees,) who are required to comply, and ensure implementation and monitoring of the ESMP.

The Project Implementation Unit (PIU) will play a central role in coordinating capacity development activities and engaging relevant experts or departments to offer trainings as outlined in Table 7- 1.

Table 7- 1: Capacity needs for other role players

ORGANIZATION GROUP	or	CAPACITY NEEDS	TRAINERS	ESTIMATED BUDGET IN US\$
Developers/Contractors		Training on implementation and monitoring of environmental and social safeguards requirements.	PIU – ESS	1,500
Department of Energy		Awareness on environmental and social safeguards requirements.	PIU – ESS	1,000
Local authorities and community		Training and awareness on grievance redress mechanism, community health and safety, including awareness on Contractor’s codes of conduct in relation to GBV/SEA, and management of HIV.	Contractors, PIU, GBV/SEA/SH and HIV experts	2,500
Developers/Contractors, Communities, local authorities, grievance redress committees, community liaison officers.		Training on GBV/SEA/SH.	PIU, One stop center by Ministry of Gender, Sports and Recreation (MGYSR) or other GBV/SEA/SH experts	14,000

Total training costs (including material and booking of venue and consultant experts)	19,000
---	--------

7.2 ENVIRONMENTAL, SOCIAL, HEALTH AND SAFETY INDUCTION

Prior to commencement of site establishment and construction activities, the Contractor shall be briefed on his obligations towards environmental and social controls and methodologies in compliance with terms of the ESMP. The PIU Environmental and Social specialist and the CLO shall be tasked with briefing the Contractor on their obligations. The briefing shall among other things include measures to protect the workers, communities, and other individuals engaged with the sub-project from health and safety risks.

An environmental and social induction shall be conducted on all new employees, supervisory staff (e.g. foreperson) and management staff arriving on site. The environmental and social induction provides a platform on which all management, supervisory staff and workers are oriented on the anticipated risks and impacts associated with the construction works, as well as how to adequately implement the proposed mitigation measures. The purpose of inductions is to ensure that all on-site personnel understand the key issues relating to the project. The education/awareness program should be aimed at all project personnel that is, personnel at all levels of management and construction workers (including sub-contractors, if engaged).

Skills necessary for the sound implementation of the ESMP and other such environmental and social requirements and training requirements for the Contractor’s personnel shall be identified by the PIU Environment and Social Safeguards specialists and the CLO. The environmental and social safeguards induction training topics shall include but not limited to the following:

- ESMP requirements, and Environmental Monitoring Checklist (Annexure 11.5);
- Gender Based Violence (GBV) and Sexual Harassment (SH), and child labor;
- ESMP non-compliance by the Contractor and consequences as stipulated in the contract;
- Health and safety requirements for the Contractor;
- Grievance Redress Mechanism (GRM).

The environmental and social safeguards induction trainings will be implemented as per the training plan shown in

Table 7-2 and shall be conducted by the PIU E&S safeguards specialist at the project site.

Table 7- 2: Environmental safeguards induction trainings

Training	Target Audience	Training Method/Trainer	Duration
ESMP requirements	Contractor (Management)	Induction	1 Day * 2
ESMP requirements	Contractor Employees	Induction	4 Hours
Grievance Redress Mechanism; GBV/SEA/SH prevention and management	Contractor Employees	Induction	1 Day
Other E&S training topics	Contractor Employees	Induction	To be confirmed

7.3 CONTRACTOR’S INTERNAL TRAININGS

All workers are to be provided with Health, Safety and Environment (HSE) training by the Contractor. Toolbox talks shall be undertaken by the Contractor in addition to the formal training done. As proof of having conducted training, a training register shall be kept on site for all trainings done for auditing purposes. The HSE training shall at minimum cover the following topics:

- Codes of Conduct (CoC) in order to reinforce workers’ understanding of expected behaviour;
- The importance of conforming with all HSE policies;
- The HSE impacts of the proposed activities;
- HSE benefits of improved personal performance;
- Worker’s roles and responsibilities in achieving conformance with the Client’s/Contractor/Developer’s HSE policy, procedures and this ESMP including associated procedures and emergency preparedness and response requirement;
- Potential consequences of departure from specified operating procedures; and
- Mitigation measures required to be implemented when carrying out their activities;

- COVID-19 prevention and management training;
- HIV/AIDS and TIP awareness;
- Chance Find procedures (see annexure 11.6); and
- Grievance Redress Mechanism.

7.3.1 TOOLBOX TALKS

Continuous training on environmental, social, health and safety issues during the sub-project will take place in the form of daily/weekly toolbox talks, by the Contractor's Environment, Health and Safety (EHS) Officer, and shall be signed by all the attendants. The toolbox talks allow specific training in an aspect of specific works carried out. Relevant or site specific environmental and social matters, incidents and issues shall therefore form part of the Contractor's toolbox talk sessions. As a recommendation, toolbox talks should be conducted in an interactive way which allows all employees and foremen to understand the content and purpose of the ESMP requirements. As with the other trainings done, the Contractor shall keep records of the subjects discussed in the toolbox talk sessions for auditing purposes.

Topics that should be included in toolbox talks include, but are not limited to:

- Safety rules;
- Traffic safety;
- Occupational health;
- Correct use of and storage of safety equipment e.g. harnesses;
- Basic health hygiene;
- Alcohol and drug abuse;
- Gender Based Violence (GBV);
- Grievance Redress Mechanism (GRM);
- Water conservation;
- "No go" areas;
- Water pollution;
- Fire prevention and management;

- Emergency response and evacuation procedures e.g. in the event of accident, electrical incident, explosion, fire, floods, etc.;
- Relationships with the local communities;
- Chance Find Procedures;
- Litter and waste management;
- Prevention and cleaning up of hydrocarbon spills.

8 STAKEHOLDER CONSULTATIONS

8.1 OVERVIEW

Apprising Project Affected Parties (PAPs) about their rights and choices is a fundamental requirement of the World Bank's safeguards policies as well as Lesotho regulations. Stakeholder consultation entails the consultation process that has been and will be undertaken for the interested and affected parties. Stakeholder consultation affords the concerned stakeholders an opportunity to contribute to both the design and implementation of the sub-project and reduce the likelihood for conflicts.

Thus, prospects are created to:

- Identify the views of local communities, key institutions and other stakeholders;
- Obtain local and traditional knowledge that may be useful for decision-making;
- Assess any mitigation measures which may be undertaken to minimize any adverse impacts of the proposed activities under the project;
- Facilitate consideration of alternatives, mitigation measures and trade-offs;
- Gather stakeholders' inputs, views and concerns; and take account of the information and views of the public in the project design and in decision making;
- Ensure that important impacts are not overlooked, and benefits maximized;
- Reduce conflict through the early identification of contentious issues;
- Provide an opportunity for the public to influence the designs and implementation in a positive manner;
- Improve transparency and accountability in decision-making; and
- Enhance public confidence in the project.

8.2 STAKEHOLDER CONSULTATIONS

In order to supplement the findings of the site visits, stakeholder consultations were done; that is, community consultation, institutional consultations and stakeholder consultations with interested and affected parties. The Lesotho Environment Act No. 10 of 2008 recognizes the importance of stakeholder consultations as an essential element of good project management practice. As such, these consultations were done in accordance with both the national and the

World Bank safeguards policies. Tools used in engaging the community included Key informants' interviews with other key stakeholders which allowed qualitative data to be gathered through these semi-structured interviews with Key Informants and the institutional consultations in sub-project areas. Semi-structured interviews were also conducted with area chiefs. Key informants were MOSCET, ONE POWER, Lesotho Electricity Company, National University Lesotho Energy Research Centre (NUL-ERC) and Department of Energy (Planning and Renewable Energy sections). Issues raised were taken into account during the impact assessment as well as in the development of environmental management and monitoring plan.

8.2.1 KEY INFORMANTS' INTERVIEWS

Key Informant Interviews (KIIs) were conducted for the purposes of informing the development of the ESMP and Project as a whole. A number of concerns and comments were raised by Interested and Affected Parties (I&APs) during stakeholder consultation process. The issues raised were taken into account during the impact assessment procedure. Environmental management and monitoring plan has also made provision for these concerns. The outcome of these interviews was used to inform development of enhancement and mitigation measures. Details of KIIs are provided in Annexure 11.7 and a summary of key issues raised is provided below.

Anticipated project benefits

- Service providers in this sector anticipate providing services in accordance with their expertise in contracting and design thereby generating income although profits may be realised after a long time. Others intend to contribute valuable research to the project based on their experience with similar mini-grid projects.
- This project will benefit the communities by providing energy access and there will be improvements in service provision in schools, health centres as well as establishment of new commercial activities that are dependent on energy access. However, a substantial subsidy is needed to reduce tariffs for end users with low financial means.

Challenges based on past experiences

Key Informants have provided the following challenges among others based on their past experiences and these which will need to be addressed in the project design and implementation:

- Accessibility challenges due to terrain during construction and maintenance. Accessibility also affects public gathering attendance and community participation leading to limited knowledge about electricity productive uses;
- Level of acceptance by the communities is low at the beginning but increases with time hence the rate of recovering costs is slow;
- Generation of e-waste – mitigations in this regard have been provided in the ESMP;
- It is difficult to find investors for Renewable Energy since there is no subsidy policy as yet in the country;
- Ability to pay for connection fee and usage is a challenge in rural areas due to socio-economic conditions of rural communities;
- The project is in remote areas where there may be rare and/or endangered bird species which may be impacted by project infrastructure;
- Severe soil erosion was experienced at Ramarothole solar plant hence, vulnerability of land to soil erosion at plant sites has to be determined;
- There may also be grievances in relation to compensation in cases where private property is impacted;
- Potential vandalism in various forms including herd boys throwing stones at solar panels.

Recommendations

- Sensitization of the communities to prevent vandalism. Also, solar plants have to be within the villages to prevent theft;
- Communities have to be educated on the importance of electricity in income generation so as to increase electricity usage;
- It would be good for local companies to partner with international companies with more financial capacity and expertise so that there may be skills transfer;
- Project communities will have to be sensitized that the equipment for mini-grids is expensive for isolated plants hence the tariff will not be the same as that of the national grid. At the same time, there has to be an understanding that infrastructure for national grid will be more expensive for communities in remote due to distances;
- Electrification strategy has to be updated to include mini-grids.

8.2.2 INSTITUTIONAL CONSULTATIONS

In Ha Nkau, three institutions with different focuses were consulted on the energy situation that is energy sources used and challenges relevant to the energy situation. All the 3 institutions consulted use different energy sources all of which are riddled with challenges that may or may not be the same. Although the way of living maybe thought to be simple and straightforward in the villages, lack of efficient energy sources complicates life in various ways.

The distribution of energy sources used in the institutions is shown in Figure 3-9 in chapter 3 while some of the challenges they currently face include unreliability of the energy of the energy sources which is experienced 33% of the respondents, effects of energy source use on safety and health outcomes (33%), lack of maintenance of solar equipment (33%) and challenges with theft or crime affecting (33%). Majority (67%) struggle with energy required for lighting and heating while 33% have their use of other electrical equipment restricted.

While the severity of these challenges varies from one subproject location to another, the graph in Figure 8- 1 outlines some of the challenges the institutions associate with energy use in the different institutions in Ha Nkau. The implementation of the project will address most of the challenges stated during stakeholder consultations.

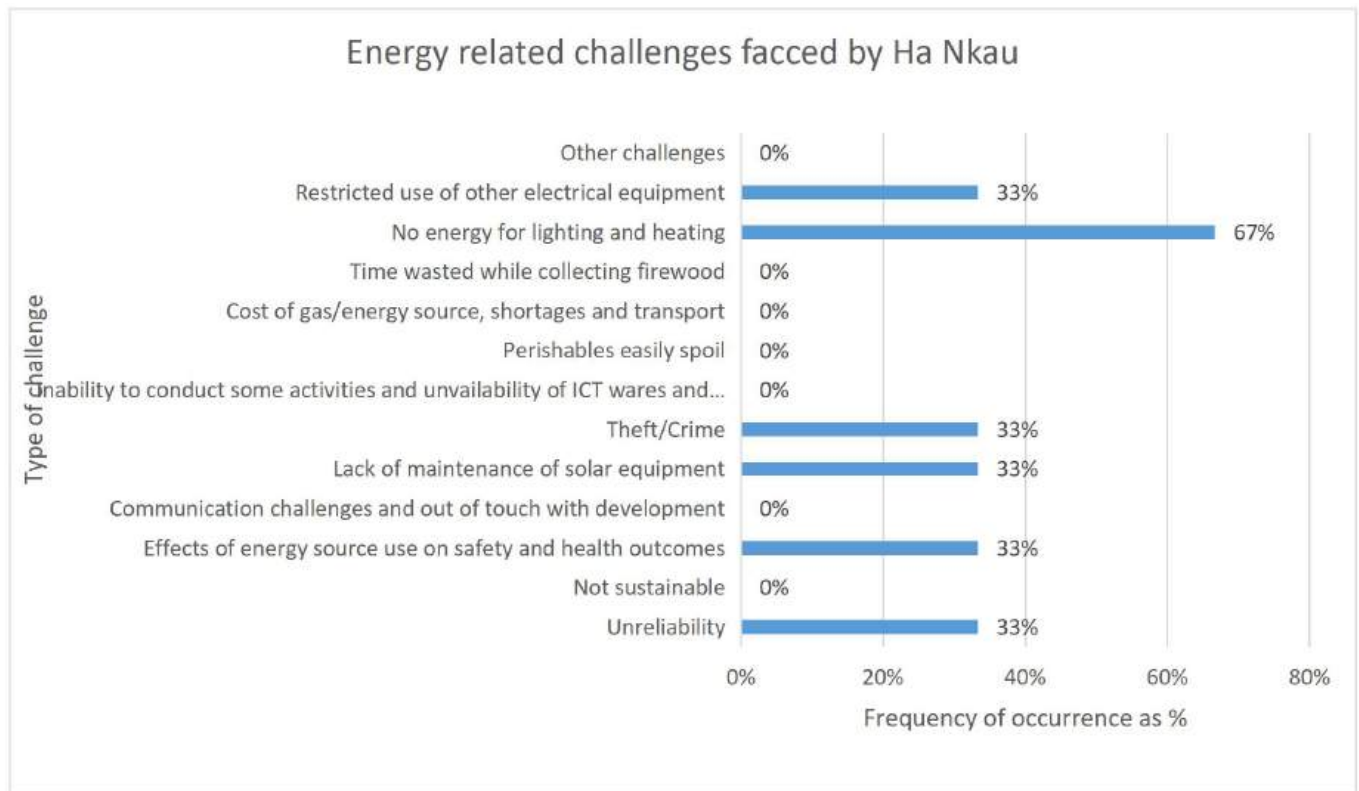

Figure 8- 1: Energy related challenges experienced in Ha Nkau

Though the project will most likely have challenges of its own, the respondents were all appreciative about the prospects of the mini-grid being located in Ha Nkau. The leadership of Ha Nkau and the people are appreciative of the initiative being put forward to electrify their villages. Some of the benefits they are expecting to draw from the project include the following and the ESMP has provided enhancement measures for these benefits:

- Access to reliable, efficient and affordable energy sources;
- Ease in the conduction of activities e.g. in school, health centres;
- Extended working duration and /or study time;
- Environmental conservation;
- Increase in safety and security;
- More equipment for production and increase in economic activities;
- Better lighting and heating.

The respondents are expectant that whatever challenges are associated with the project can be mitigated in the best way possible in the interest of both the community and the Developer. Some of the recommendations that were put forward to mitigate against foreseen environmental, social and security challenges that will be brought about by the proposed project in Ha Nkau as well as enhancing project effectiveness include:

- Community sensitization on the project and its associated risks;
- Provision of security services;
- Development of a code of conduct;
- Recruitment from Ha Nkau village and utilization of local stores to buy wares;
- Community liaison;
- Rotation of workers for fairness and ensuring gender equality.

The above recommendations have been considered in the development of mitigation measures in particular in the integration of migrant workers into the project communities.

8.2.3 CONSULTATIONS WITH LOCAL AUTHORITIES

Stakeholder consultations with Ha Nkau area chiefs were conducted using a semi-structured questionnaire. In light of their roles within the villages, chiefs were consulted on development issues that affect the community with focus on energy related concerns. Guiding questions are provided in annexure 11.7.2 and below is a summary of outcomes of the consultations. These were considered in impact assessment as well as development of enhancement and mitigation measures.

POSITIVE IMPACTS/BENEFITS OF ENERGY

- The initiative to continue involving and updating the community and leadership on the Project's progress was highly appreciated and highly recommended as it may contribute to project ownership, reducing negative impacts such as theft;
- Energy is essential for household chores such as cooking, lighting, and heating homes. Women spend time collecting firewood and. They often make these trips alone and must travel to isolated areas to gather sufficient fuel, putting them at risk of harassment and sometimes rape. Availability of a reliable source of energy will reduce need for women to go to isolated areas to look for firewood;

- Some schools have a feeding scheme, and children sometimes have to leave lessons to collect firewood. Where schools are connected to solar need for firewood collection is eliminated in turn improving efficiency of the school feeding programme;
- The Project will contribute to improving security within the villages. High levels of theft will be reduced, as most crimes occur at night.

NEGATIVE IMPACTS:

- Some proposed projects communicated to the communities take a long time before implementation. Some end up not being implemented. The result is a lack of trust in the Government's proposed projects and reluctance to participate in community engagement for proposed projects/initiatives;
- Construction workers have contributed to adverse impacts within villages. The most common are high incidences of pregnancies and family breaking up; they tempt women and girls with money;
- The project may increase theft rate as villagers may be tempted to steal the panels.

MITIGATION STRATEGIES:

- Panels will have to be protected from theft. The area should be fenced, and the community or the Government should provide security guards. Community members may contribute to pay guards;
- The Project should train community members on how to use electricity and some precautions to take;
- The Project should raise the desire of the community to have ownership of the Project to vandalism or theft. The chiefs and councilors could create awareness on an ongoing basis.

It also important to note that that there were consultations with local authorities as part of the feasibility studies and the outcomes are provided in annexure 11.7.3. The outcome informed the project design especially in terms of the scope of villages to be covered.

8.3 INFORMATION DISCLOSURE

LREEAP ESMF states that the project will engage with stakeholders, including communities, groups or individuals affected by the project and other interested parties, through among

others information disclosure. The ESMP is to be publicly disclosed by LREEAP as the agency responsible for implementation of the project. The ESMP executive summary should be made available online by LREEAP. Other methods of information dissemination will also include newspaper advertisements, radio or television programs, and the distribution of Project Information Sheets, news updates and posters through, or displayed in, public places such as schools, health centres, and market places. These information dissemination methods will alert the public to the disclosure of the instruments. Department of Environment and LREEAP will ensure that several copies of all prepared safeguards instruments are available locally at their respective offices, easily accessible to affected groups and local NGOs. These copies will be availed in a language best understood by the readers that is in Sesotho and English.

The ESMP is a living document, as such reviews and updates on it will be done as and when required throughout the project lifecycle. With each review and update made to the ESMP, LREEAP will be tasked with disclosing such changes in the new versions thereof through the channels above.

8.4 GRIEVANCE REDRESS MECHANISM (GRM)

Grievance redress mechanism provides a system through which complaints or grievances can be received, processed and resolved in a timely, effective and efficient manner that satisfies all parties involved. Its relation to citizen feedback, incorporation of community consultation, concerns and complaints about project's environmental and social performance and engagement make it a key component of the project.

A Grievance Redress Mechanism (GRM) upholds the project social and environmental safeguards performance. The Grievance Redress Mechanism (GRM) works within the existing legal and cultural frameworks, providing additional opportunity to resolve grievances at the local project level.

The key objectives of the GRM are as follows:

- Record, categorize and prioritize project related grievances;
- Settle grievances via consultation with all stakeholders and inform those stakeholders of the solution; and
- Forward any unresolved cases to the relevant authority.

Culturally, Lesotho has an existing and functional community based grievance redress systems. This is achieved through local traditional authorities such as chiefs and local community councillors who have proved to be effective. The parties involved have their grievances settled by the chief with the help of the community leaders where there is need. In instances where the grievances fail to be settled the matter can be referred to a community court.

As the GRM works within existing legal and cultural frameworks, it is recognized that the GRM will comprise community level and project level redress mechanisms.

8.4.1 GRIEVANCE REDRESS COMMITTEE

A functional Grievance Redress Committee will also be established for this sub-project. The Committee will be able to address people’s concerns and if the grievance is still not addressed, the committee allows people to appeal upwards even to the legal courts of law as stipulated in Chapter 10 of the LREEAP Resettlement Policy Framework.

As a monitoring tool for grievances, a recommendation grievance form is attached below.

Table 8- 1 Sample Grievance form – Ha Nkau solar mini-grid

Name of village	Name of Complainant	Complainant Contacts	Date of complaint	Summary of Complaint	Action taken	Date of action	Completion date

The possible structure of a functional Grievance Redress Committee (GRC) may entail of the following personnel: chief, community council representation, Contractor/Developer SHE officer, LREEAP Community Liaison Office (CLO) and 3 members (I.e. Male adult, Female adult, and Youth) of the project affected community. It is also recommended that the GRC at the sub-project level, collaborate with GRC at the project level for effective management of the project grievances. The project level GRC may entail the following personnel: LREEAP Environmental and Social Specialist (who coordinate the GRC), LREEAP Mini grid manager, Department of Energy Representative, and Contractor/Developer project manager.

8.4.2 ACCESSIBILITY OF THE GRM

Each received grievance will be recorded in the GRM forms and the Logbook (there will be a separate Logbook for GBV/SEA/SH complaints), and submitted to the GRC by the CLO. The Safeguards team, with assistance of CLO, will ensure that the GRM is accessible to all stakeholders, including rural communities and vulnerable groups, through specific measures that will be agreed upon, during consultations with these stakeholders. The GRM will also allow anonymous grievances to be raised and addressed.

Submission of grievances may be done orally, in writing, or through emails, SMS, or walk-in at the Contractor's office or project office. In order to facilitate the reporting of grievances by community members or workers, a grievance box will be installed at a conveniently accessible location within each mini-grid site. The grievance box will prominently display the receiving email address and phone numbers for grievances, ensuring clarity and ease of communication for those wishing to submit their concerns.

8.4.3 GRIEVANCE REDRESS PROCESS

Grievances will be lodged through CLO and the complaints will be shared with the GRC as soon as possible or within 24 hours for initial report. The respondent (CLO) with whom the grievance is lodged or referred should meet with the complainant within two working days of receiving the complaint and immediate action should be taken to resolve the issue.

The investigation will be conducted within five working days of meeting with the respondent, and other issues should not delay the investigation. Following investigation completion, parties should be notified of the results within two working days.

In case one party is not satisfied with the decision at the certain level, one can appeal to upper level. CLO will act as focal point, and perform the liaison functions among the Contractor, Communities, and GRC in processing the grievances. Grievance Logbook will be maintained at the Contractor's office.

If the complainant is not satisfied with the resolution provided at the sub-project level, the grievance can be elevated to the project level for treatment of by PMU through the Environmental and Social Specialist within two weeks of receipt of the grievance by the PMU. If not satisfied with the decision at project level, department level, or ministerial level, he/she may take the case to the office of the Ombudsman, Judiciary or to the World Bank Grievance

Redress Service (GRS) within one week of resolution, or else the case will be closed. The grievance mechanism provides linkages to the national legal system.

8.4.4 MANAGING GBV/SEA/SH RELATED GRIEVANCES

The proposed GRM procedures should allow for the immediate GBV/SEA/SH case reporting and provide for immediate referral of survivors to GBV service providers (e.g., allow for immediate reporting of rape case to Police Office, and allow for survivors to seek medical attention within 24 hours for HIV prevention and emergency contraception). Due to the sensitivity of SEA/SH cases, these grievances will be managed separately from other types of grievances and will not be documented in publicly accessible Logbook. Reporting channels for GBV/SEA/SH cases shall be varied to allow for anonymous reporting and they will be accessible, safe and confidential for survivors. The following process shall be followed to verify SEA/SH complaints:

- Provision of SEA/SH Logbook for recording of SEA/SH complaints received. This Logbook shall record case numbers, identifier code, age and gender of the survivor, type of SEA/SH offence, whether or not the survivor was referred for services and status showing whether the case is pending or closed. Survivor identities will only be disclosed to GBV service providers;
- All complaints shall be referred to Lesotho Mounted Police Services (LMPS) Child and Gender Protection Unit and health service providers immediately for walk in cases within 48 hours for cases reported telephonically. However, for sexual assault, referrals shall be made within 24 hours;
- The PMU shall provide the World Bank the following information within 24 hours of receiving notification of SEA/SH complaint: case number; age and sex of the survivor, whether the survivor was referred for services and status.

8.5 MEASURES TO ENSURE CONTINUED STAKEHOLDER ENGAGEMENT THROUGHOUT THE PROJECT LIFE CYCLE

It is critical to ensure engagement of all relevant stakeholders including project affected parties (including those who may be disadvantaged or vulnerable) and other project interested parties throughout the life cycle of the project. It is recommended that the following be implemented to ensure continued engagement:

- Continuous identification of and consultation with relevant stakeholders including but not limited to:
 - Project affected parties;
 - Other interested parties;
 - Authorities;
 - Service providers.
- Development of communication tools and methods using appropriate language (e.g. use of Sesotho during community gatherings) for different stakeholder groups. This may include:
 - Meetings and workshops;
 - Electronic communications, including telephones, emails or letters;
 - Public gatherings (Lipitso);
 - Media – radios, local television, and local newspapers;
 - Social media.
- Stakeholder consultations with communities should be on going and may include the following:
 - Gatherings to introduce the project, the appointed Contractor, explaining the GRM as well as community workers’ recruitment processes;
 - The Contractor may also hold community gatherings when need arises during the construction phase, coordinated by the project CLO.
- Collective and one-on-one consultations with persons whose properties are likely to be impacted.

Indicators for stakeholder engagement:

- Communication tools developed;
- Number of stakeholders consulted;
- Number of meetings and workshops organized as well minutes;
- Number of participants attending public gatherings (indicating male and female participation);
- Number of stakeholder groups identified and engaged by the subproject;

- Number of stakeholder feedback;
- Stakeholder concerns addressed and communicated.

9 IMPLEMENTATION SCHEDULE AND COST ESTIMATES

This section, including Table 9- 1 provides a summary of implementation schedule for measures that should be carried out as part of the sub-project for different phases as well as coordination with overall project implementation plans as well as cost estimates. Appropriate financial provision should be made for environmental and social management of the sub-project to ensure that the costs of the mitigation measures required are covered. The budget has been derived from the environment and social impacts management measures, team inductions and other training requirements.

The total cost estimate has been determined primarily based on twelve (12) months construction period that is anticipated for the mini grids. The cost of the project is assessed according to the management of environmental and social risks or impacts of physical, socio-economic, occupational health and safety (OHS), as well as cultural aspects that influence the project.

The projected cost for ESMP implementation is fifty-nine thousand, six hundred and thirty-nine United States Dollars and sixty-five cents (**US\$59,639.65**) using the exchange rate of 18.70 LSL to 1 US\$ which is mainly for the construction phase with anticipated duration of 12 months for this mini-grid. The cost estimate for monitoring will be included in the project as monitoring will be done by LREEAP staff. Training costs shall be carried out by the LREEAP – PIU therefore the total cost estimation shall be **US\$ 19,000** covered in the project operational budget.

The overall cost estimation including 10% contingency price for the mini-grid in Ha Nkau is seventy thousand, seven hundred and seventy-five United States Dollars, and sixty-eight cents (**US\$ 70,775.68**).

Table 9- 1: Overall cost estimation for the Ha Nkau mini-grid

ASPECT	COST ESTIMATION (US\$)/MINI-GRID SITE Exchange rate 18.70 LSL to 1 US\$
ESMP Implementation	59,639.65
Monitoring	Included in the project cost
Training	19,000
Total	78,639.65
Contingency (10%)	7863.97
GRAND TOTAL	70,775.68

10 INTEGRATION OF THE ESMP WITH PROJECT

It is the responsibility of the Project Implementation Unit (PIU) under the Department of Energy (LREEAP PIU) to ensure that the ESMP is fully integrated into the project implementation documents. The ESMP shall form part of any bid documentation, and it shall be the PIU's responsibility to ensure that the technical requirements and data sheets of project bid documentation is subject to review against this ESMP to ensure that all appropriate safeguards measures are captured at the bid stage. Adjudication of the tenders must include an assessment of the Developer/Contractor's environmental and social Policy, their proposals for environmental management on site, appointment of suitably qualified SHE Officer and environmental and social track record.

The safeguards requirements for any design or supervision of the project will be fully integrated into Terms of Reference (ToR) to ensure that all safeguards responsibilities allocated within the ESMP are realized at the tender stage. In this way, the ESMP will be fully integrated within the Project so that the required measures will be fully appreciated by all responsible parties and successful implementation will be achieved.

11 ANNEXURES

11.1 REFERENCES

Government of Lesotho legislation:

- Labour Code of 1992;
- The Lesotho Labour Code (Amendment Act No. 3 of 2000);
- Environment Act No. 10 of 2008;
- Constitution of Lesotho of 1993;
- Local Government Act No. 6 of 1997;
- Public Health Order No.12 of 1970;
- National Heritage Resources Act No. 8 of 2011;
- Land Act No. 8 of 2010;
- Legal Capacity of Married Persons Act No. 9 of 2006;
- Lesotho Energy Policy (2015-2025);
- Decentralization Policy of 2014;
- Forestry Act No 91 of 1998;
- Legal Capacity of Married Persons Act No9 of 2006;
- Workmen’s Compensation Act No. 13 of 1977;
- Penal Code Act No. 6 of 2012;
- Children’s Protection and Welfare Act No. 7 of 2011;
- Sexual Offences Act of 2003;
- Lesotho Gender and Development Policy 2018-2030; and
- National Environmental Policy of 1998.

Relevant International Conventions and Standards to which Lesotho is signatory:

- World Bank Environmental and Social Standards;
- Stockholm Convention on Persistent Organic Pollutants;
- Montreal Protocol;
- SADC Declaration on Gender and Development;
- United Nations Framework Convention on Climate Change (UNFCCC).

- Kristine (2023) *What is the difference between fixed and single axis trackers?*, *SolarFeeds Magazine*. Available at: <https://www.solarfeeds.com/mag/what-is-the-difference-between-fixed-and-single-axis-trackers/> (Accessed: 02 May 2024).
- Leketa, K., Migwi, M., Crane, E., Upton, K. Dochartaigh, B., Bellwood-Howard, I, 2018. *Hydrology of Lesotho*, British Geological Survey. Available at: <http://Earthwise.bgs.ac.uk/index.php/hydrogeology-of-lesotho>.
- Mtetwa, S. and Monare, N. (2018) *Vol 1, Lesotho Nutrition And Health System Strengthening Project (LNHSSP) Environmental And Social Management Framework (ESMF)*. Government of Lesotho.
- UNFPA Lesotho (2020) *UNFPA Lesotho | United Nations Population Fund*. Available at: <https://www.unfpa.org/data/LS> (Accessed: 08 March 2024).
- Belle, J. A., Ferriera, S. B., & Jordaan, A. (2013). *Attitude of Lesotho health care workers towards HIV/AIDS and impact of HIV/AIDS on the population structure*. *African health sciences*, 13(4), 1117–1125. <https://doi.org/10.4314/ahs.v13i4.36>
- Nseera, E. (2014), *Growth and Distributional Impact of Agriculture, Textiles and Mining Sectors in Lesotho* Working Paper Series N° 206 African Development Bank, Tunis, Tunisia.
- Lesotho Electricity Company, 2019. *Environment and social management framework: Lesotho renewable energy and energy access project*. Maseru
- Lesotho Electricity Company, 2019. *Resettlement Policy Framework: Lesotho Renewable Energy and Energy Access Project*. Maseru.
- NES (2000) *National Strategy on Lesotho's Biological Diversity: Conservation and Sustainable Use, National Environment Secretariat*. Maseru: Ministry of Tourism, Environment and Culture;
- Newton D., Letsela, T., Lijane, T., Mafatle, N., Manyama, P., Naha, S., Ntloko, B., Ntsohi, R., Paetzold, B., Pires, A., Polaki, M., Raimondo, D., Rouget, M., Tšele, T., Wistebaar, N., and Zimudzi, C. 2008, *Development of a Non- Detriment Finding Process for Pelargonium Sidaoides in Lesotho*. Available at: https://cities.org/sites/default/file/ndf_material/WG2-CS2-S.pdf

Panigrahy, S. *et al.* (2016) 'Numerical and experimental analyses of LPG (liquefied petroleum gas) combustion in a domestic cooking stove with a porous radiant burner', *Energy*, 95, pp. 404–414.

World Health Organization (1999). *Guidelines for community noise*. World Health Organization. <https://apps.who.int/iris/handle/10665/66217>. Accessed December 2022

11.2 LIST OF ASSOCIATED REPORTS AND PLANS

- Environment and Social Management Framework (ESMF);
- Preliminary Environmental and Social Impact Assessment (PESIA);
- Project Implementation Manual (PIM);
- Resettlement Policy Framework (RPF);
- Project Appraisal Document;
- Technical advisory (TA) document;
- Feasibility Studies, Needs Assessment and System Sizing for Mini-Grids in Lesotho – Technical, Financial and Socio-Economic Feasibility Analysis – Ha Nkai Report.

11.3 IMPACT ASSESSMENT METHODOLOGY

The impact assessment process which determines environmental significance on the basis of the consequence of the impact on the environment and the likelihood of the impact occurring has been utilized.

The methodology derives environmental significance using the Extent of Impact, Duration of Impact, Intensity and Probability of Occurrence of Impact, and it is in line with the assessment criteria specified in the Environmental Assessment Guidelines of Lesotho, where:

Extent of impact refers to the spatial extent of the activity or the impact.

Rating of Impact Extent

Rating	Description
1	Limited to site and immediate surroundings
2	Extending as far as the local community
3	Regional - affecting other regions outside the vicinity of the project site
4	National – affecting the entire country
5	International

Duration of impact refers to the temporal extent of the impact.

Ratings for Impact Duration

Rating	Description
1	Immediate – temporary/less than a year/ quickly reversible

2	Short term – 1-5 years
3	Midterm – 6-15 years or reversible over time
4	Long term – impact will cease after the operation phase of the project
5	Permanent

Intensity of impact refers to the severity of the disturbance caused by the impact.

Ratings for Impact Intensity

Rating	Description
1	Negligible – impact does not affect environmental processes
2	Low – where the impact slightly affects environmental processes
3	Moderate – environmental functions and processes continue but in a modified way
4	High - environmental functions and processes are altered such that they temporarily cease
5	Very high – environmental functions and processes are altered in such a way that they permanently cease

Reversibility: An impact is either reversible or irreversible. A scale of the level of reversibility if an impact is / how long before impacts on receptors cease to be evident.

Reversibility (R) Rating of Impact

Score	Description
1	Impact is immediately reversible.
3	Impact is reversible within 2 years after the cause or stress is removed; or
5	Activity will lead to an impact that is in all practical terms permanent.

Probability of occurrence: refers to possibility of that impact taking place during the project.

Rating and Assessment of Impact Probability

Rating	Description
1	Unlikely – the likelihood of the impact occurring is very low due to design, historic experience, or implementation of adequate measures
2	Low – there is a low likelihood that the impact may occur
3	Medium – the impact may occur
4	High – it is most likely that the impact will occur
5	Definite – impact will occur regardless of implementation of any preventative measures or if the specialist does not know what the probability will be based on too little information

Cumulative impact: the impact of the project is considered together with additional developments of the same or similar nature or magnitude. The combined impact may be:

- **Negligible** – the net effect is the same as the single development;
- **Marginal** – the impact of two developments is less than twice the impact of a single development, implying that it is better to place the same developments in the same environment than in separate environments;
- **Compounding** – the impact of two developments is more than twice the impact of two single developments, implying that is better to split the two developments into separate environments.

Environmental significance links all of the above parameters to infer the consequences of the impact on the biophysical and socio-economic environment. The spatial extent (E), duration (D) and intensity (I) as well as reversibility (R) together comprise the consequence (C) of the impact such that $C = (E+D+I+R)$. The values of probability (P) and consequence (C) are then multiplied to obtain the significance (S) ratings. Therefore, significance $S=C*P$.

Ratings for Impact Significance

Rating	Description
4-15	Very low
16-30	Low
31-60	Medium
61-80	High
81-100	Very high

11.4 CODE OF CONDUCT

This Code of Conduct is developed as guidelines and rules outlining how personnel should interact at workplace. It is developed to ensure that a workplace promotes a fair treatment, non-discrimination and equal opportunities to all personnel including vulnerable workers such as women, people with disabilities and migrant workers. The Code of Conduct is in accordance with the International Labour Organization (ILO) fundamental Conventions as stated in section 2.2.5 of this ESMP. The CoC provides guidelines on acceptable and appropriate behaviours at workplace and measures for conflict resolution.

ETHICAL AND BEHAVIOURAL STANDARDS

The Code of Conduct defines the ethical requirements and standards for Contractor personnel. It provides the behaviour prohibited and behaviour and ethics required from all the Project personnel. It further states that personnel should feel free in reporting issues without fear. It is the responsibility of the Contractor to ensure that all workers and Sub- contractors comply with ethical requirements and standards as set forth in this Code of Conduct. Failure to comply with may lead to disciplinary hearing or termination of work contract. The following are ethical and behavioural standards:

- Personnel must not engage in any abuse of vulnerable people and communities;
- Personnel will respect all persons equally without distinction of race, gender, sexual orientation, age, socio-economic status and more;
- There shall be zero tolerance for abuse and misconduct, including sexual exploitation and abuse, sexual and work place harassment, discrimination, assault, and threatening or jeopardizing the lives or wellbeing of colleagues or others;
- Personnel must not abuse any associated privileges and immunities granted by hosting line ministries.

LABOUR RIGHTS AND HUMAN RIGHTS

Non-Discrimination and equal opportunities at workplace: The Contractor should not support and engage in workplace discrimination of any form. Hiring, remuneration, benefits, training, advancement, discipline, termination, retirement or any other employment related decision shall not be biased.

Health and Safety at workplace: The Contractor should ensure a safe working environment for the employees. This includes provision of appropriate protective clothing and equipment and provision of training.

Forced labour: Workers should not be forced to accept employment or be engaged against their will. Contractors must respect workers freedom to leave the work if they wish to do so.

Working hours and breaks: It must be ensured that working hours comply with the labour code order and its amendments and other international best practices.

Child labour: Contractor must not engage a child. A child is defined as a person under the age of 18.

REQUIRED CONDUCT FROM PERSONNEL:

- Women and children shall not be discriminated. They will be treated with equal respect and never be placed in compromising situations;
- Personnel shall not engage in sexual intercourse with a child under 18 years unless in the case of pre-existing marriage;
- Unwelcome sexual advances or sexual harassment of any form are prohibited. Verbal or physical sexual conducts including requests for sexual favours in exchange of employment, goods and services for sex is unacceptable;
- Sexual exploitation in exchange for benefits from Project's goods, and service benefits shall not be engaged in;
- Attempted rape, rape, gang rape and other forms of rape are prohibited;
- Sexual assault meaning non-consensual contact –without penetration, is forbidden;
- Personnel should not engage in sexual relationships with crisis-affected populations since such relationships are based on imbalanced power dynamics and undermines the credibility and integrity of this code of conduct.

RAISING CONCERNS

In the case whereby the code of conduct is violated, the observer must raise the issue promptly in the following steps:

- i. Launch a complaint using reporting channels;

- ii. The reporter’s identity must be kept confidential. All the reports, anonymous complaints and known shall be submitted and given all the consideration that is due and appropriate. It is essential that the confidentiality and safety of GBV survivors is protected;
- iii. Investigations must be carried out in case of a possible misconduct and appropriate action shall be taken;
- iv. Recommendations shall be provided to service providers in order to comfort the alleged victim of the incident.

11.5 MONITORING CHECKLIST

Inspection Date & Time:Site Name:

Project Phase:Activities:

Environmental and Social Specialist (ESS):

C = Compliant

NC = Non-Compliant

PC = Partially Compliant

N/A = Not Applicable

Ref.	ESMP Commitment	C	NC	PC	N/A	Evidence	Corrective Action Required
	PRECONSTRUCTION PHASE						
1.	SITE CLEARANCE AND CAMP ESTABLISHMENT						
1.1	Vegetation removal is limited to areas where removal is thereof necessary;						
1.2	Care taken to ensure medical plants and endangered species are rescued to a conservation area that shall be approved of;						

Ref.	ESMP Commitment	C	NC	PC	N/A	Evidence	Corrective Action Required
1.3	No chemical vegetation control utilized during clearing;						
1.4	Erosion control gabions used to reduce soil erosion;						
1.5	Disposal of spoil done at a site approved by ESS;						
1.6	Spoil awaiting collection barricaded;						
1.7	Construction Camp Placement: <ul style="list-style-type: none"> • Consultation with local authorities, landowners, ESS; • Approval by LREEAP environmental and social specialist; 						
1.8	Construction camp planning and design consider waste sorting, storage, and removal;						
1.9	Construction camp planning and design ensure well-thought-out environmental processes;						
1.10	Site Construction Guidelines <ul style="list-style-type: none"> • No permanent structures at Camp; • All buildings built on screed slabs; • Decommissioning involves removal of slabs; 						
1.11	All temporary structures soundly built and not posing any danger to personnel;						

Ref.	ESMP Commitment	C	NC	PC	N/A	Evidence	Corrective Action Required
1.12	Construction camp is fenced;						
1.13	Cooking facilities supplied for the personnel housed at the construction camp;						
1.14	Fire is only be made at designated areas.						
CONSTRUCTION PHASE							
2	EXACERBATED SOIL EROSION						
2.1	Temporary drainage installed for erosion control;						
2.2	As little topsoil as possible removed whilst clearing vegetation within the construction areas;						
2.3	No stockpiling of spoil (excess soil) is performed all over the area during site clearing;						
2.4	Topsoil stored and protected from erosion;						
2.5	Excavated areas are backfilled and properly compacted to avoid soil erosion.						
3	VISUAL IMPACT OR LOSS OF ENVIRONMENTAL AESTHETICS						
3.1	Disposal of spoil done at a site approved by ESS and local authorities;						

Ref.	ESMP Commitment	C	NC	PC	N/A	Evidence	Corrective Action Required
3.2	Spoil awaiting collection has been barricaded;						
3.3	The project allowed vegetation to naturally re-establish in the cleared areas.						
4	SOIL AND WATER POLLUTION						
4.1	Products such as lubricants, oil and fuel spillages are properly stored in their designated storage areas;						
4.2	A spill response procedure is prepared and displayed;						
4.3	Mobile toilets are emptied, sufficiently cleaned, with no leakages and protected from vandals;						
4.4	Arrangement made with the residents for workers working outside the camp to use their toilets;						
4.5	Wastewater managed through water conservation and recycling;						
4.6	Timely collection and treatment of wastewater.						
5	SOLID WASTE MANAGEMENT						
5.1	A waste management plan in place;						
5.2	All work sites are kept free of construction waste and litter;						

Ref.	ESMP Commitment	C	NC	PC	N/A	Evidence	Corrective Action Required
5.3	All waste sorted at source;						
5.4	All waste that can be recycled (e.g. paper, glass, tin, cement bags, wood, cardboard etc.) is reused;						
5.5	Hazardous waste is disposed in line with national and international laws and disposal procedures;						
5.6	Provision of waste bins with lids and clearly labelled for different types of waste;						
5.7	Burning or burying of litter on site is prohibited;						
5.8	A suitable location for disposal of waste is identified, in consultation with local authorities;						
5.9	All refuse is disposed weekly;						
5.10	Daily cleaning on construction spoil;						
6	AIR POLLUTION						
6.1	Regular dust suppression;						
6.2	Water is sprayed during loading of rubble for transportation;						
6.3	A dust monitoring register is kept;						

Ref.	ESMP Commitment	C	NC	PC	N/A	Evidence	Corrective Action Required
6.4	A valid water use and abstraction permit;						
6.5	Dust nets/dust buckets are placed around areas of high dust generation;						
6.6	Dust masks provided to workers.						
7	NOISE POLLUTION						
7.1	Control of noise to levels within the allowed limits of exposure, i.e. noise levels not to exceed 70 dB (A) during daytime hours (0700 to 2200hrs and 55 dB (A) at night time (2200 to 0700hrs) for residential or institutional receptors;						
7.2	Standard working hours are adopted and strictly adhered to;						
7.3	Silencers installed on equipment where possible;						
7.4	A noise monitoring register is kept;						
8	GENERATION AND EXPOSURE OF HAZARDOUS WASTE OILS/CHEMICALS						
8.1	Hazardous chemicals/ oils are stored in a hazardous substances storage area;						
8.2	Hazardous substances storage area clearly labelled, banded and protected from elements;						

Ref.	ESMP Commitment	C	NC	PC	N/A	Evidence	Corrective Action Required
8.3	Hazardous chemicals are handled by authorized personnel;						
8.4	Petroleum products awaiting use are safely stored in designated and approved storage areas;						
8.5	Waste petroleum products are collected, stored in the waste storeroom and transported to certified waste oil collection companies.						
9	NATURAL RISKS/DISASTERS						
9.1	Works do not continue during heavy precipitation;						
9.2	Emergency planning procedures that manage the impacts of extreme events related to weather elements and climate change are developed.						
10	LOSS OF LIVELIHOODS/ PROPERTY/ LAND/ RELOCATION OF COMMUNITY UTILITIES						
10.1	Continuous community liaison;						
10.2	ARAP prepared;						
10.3	Records of affected assets and compensations.						
11	EMPLOYMENT CREATION						

Ref.	ESMP Commitment	C	NC	PC	N/A	Evidence	Corrective Action Required
11.1	Records of employed labourers available;						
11.2	No influx of job seekers at the construction site.						
12	SKILLS DEVELOPMENT						
12.1	Records of trainings for unskilled labour and other personnel;						
12.2	Skilled and semi-skilled labourers from local authorities engaged.						
13	TRAFFICKING IN PERSONS						
13.1	Awareness campaigns for trafficking in persons;						
14	HIV/AIDS, GBV AND SEA/SH						
14.1	Recruitment is done locally as far as reasonably possible;						
14.2	Capacity building opportunities to support the local communities' activities – for GBV mitigation and response;						
14.3	Code of conduct explained and signed by every employee upon engagement;						
14.4	Continuous awareness raising on sexual exploitation and GBV in Project areas;						
14.5	Employees have clear understanding of HIV/AIDS and associated						

Ref.	ESMP Commitment	C	NC	PC	N/A	Evidence	Corrective Action Required
	preventative measures;						
14.6	Employees have access to HIV testing services, free preventative commodities, ART and GBV referral system.						
15	PHYSICAL ARCHAEOLOGICAL AND AREAS OF CULTURAL SIGNIFICANCE						
15.1	Chance find procedure in place and workers trained about it;						
15.2	Provision of a list of possible heritage sites.						
16	CONFLICTS						
16.1	Continuous community liaison;						
16.2	Code of Conduct signed by all employees;						
16.3	Recruitment is done locally as far as reasonably possible;						
16.4	Grievance Redress Mechanism (GRM) in place;						
16.5	Rotation among the unskilled labourers is done to ensure fairness in recruitment.						
17	THEFT/VANDALISM						
17.1	Security in place at all times;						

Ref.	ESMP Commitment	C	NC	PC	N/A	Evidence	Corrective Action Required
17.2	Community sensitisation records.						
18	OCCUPATIONAL HEALTH AND SAFETY						
18.1	SHE Officer and SHE representatives in place;						
18.2	Compiled method statements for activities that are risky to both the environment and employees;						
18.3	Health and Safety Plan inclusive of baseline risk assessment, fall protection plan as well as other safe work procedure;						
18.4	Establishment of safety rules in the construction site and application of instructions and rules of hygiene;						
18.5	Emergency drills at least once a month;						
18.6	A trained First Aider and fully-equipped First Aid Kit on site at all times;						
18.7	Emergency contacts list displayed at strategic locations throughout the construction site;						
18.8	Adequate PPE/C provision;						
18.9	Staff management;						
18.10	Warning signs for places at risk;						

Ref.	ESMP Commitment	C	NC	PC	N/A	Evidence	Corrective Action Required
18.11	Safe drinking water provided and adequate (1 toilet to 20 workers) ablution facilities for workers;						
18.12	Separate toilet provided for males and females.						
19	PUBLIC SAFETY						
19.1	Adequate safety signage warning the public of safety risks, as well as traffic calming signage;						
19.2	Employ flagmen when required;						
19.3	Limited access to construction site by the public;						
19.4	Construction vehicles adhere to speed limits.						
20	FIRE RISKS						
20.1	Fire contained and not made in windy conditions;						
20.2	Fire only be made at designated areas;						
20.3	Workers make sure that fires are completely put out with water or sand or other measures;						
20.4	Regular inspection and servicing of basic firefighting equipment on site, including operational fire extinguishers that are mounted, easily accessible and signage indicating their position;						

Ref.	ESMP Commitment	C	NC	PC	N/A	Evidence	Corrective Action Required
20.5	Fire marshal is trained and is the first point of contact for any fire detected on site;						
20.6	Staff training and drills on fire emergencies;						
20.7	Contact details of the local fire department in place.						
OPERATION PHASE							
21	COMMUNITY ISSUES						
21.1	Subsidized tariffs to accommodate for poor households within the different communities;						
22.2	Recruitment locals for skilled, semi-skilled and unskilled as far as reasonably possible;						
22.3	Power line and system maintenance to ensure reliable energy supply.						
23	AVIFAUNA COLLISION						
23.1	Aligning transmission corridors to avoid critical habitats (e.g. nesting grounds, bearded vultures foraging corridors, and migration corridors).						
23.2	Visibility enhancement objects such as marker balls, bird						

**ENVIRONMENTAL AND SOCIAL MANAGEMENT PLAN FOR HA NKAU
SOLAR MINI GRID**

2024

Ref.	ESMP Commitment	C	NC	PC	N/A	Evidence	Corrective Action Required
	deterrents, or diverters installed.						

11.6 CHANCE FIND PROCEDURE

CHANCE FIND PROCEDURE FOR HA NKAU SOLAR MINI-GRID PROJECT

This is a procedure that outlines actions required if previously unknown heritage resources, particularly archaeological resources, are encountered during project implementation. Physical cultural resources and heritage remains are finite, non-renewable and highly susceptible to disturbance. They are managed for their historical, cultural, scientific, and educational importance and value to the general public, and local communities.

PURPOSE

The purpose for the Chance Find Procedure for the Construction of Ha Nkau solar mini-grid is to prevent archaeological resources from being disturbed during the project implementation and to provide protocol to follow in the case of a chance archaeological find to ensure that archaeological sites are documented and protected as required.

SCOPE

Within the sub-project's footprint, LREEAP carries the full responsibility within the scope of its ESMP.

DEFINITIONS

Heritage - living heritage, sites and objects of heritage significance;

Heritage Authority - the Department of Culture, its representation within the District and the District Council Office representatives charged with the responsibility of ensuring compliance to the provisions of the National Heritage Resources Act No.8 of 2012.

PROTOCOL

Cultural Heritage Management Protocols are largely extrapolations from legislation:

- The National Cultural and Natural Heritage Authority now known as the Department of Culture in the Ministry of Tourism, Environment and Culture was established to oversee and manage heritage resources. Any form of cultural and natural heritage feature identified within the project area shall be documented in consultation with the

Department. The Client (Ministry of Energy) shall document heritage that is likely to be directly or indirectly affected by its activities;

- Continuous inspections shall be undertaken for the items that are underground to prevent negative impacts and also be able to minimise those that are inevitable, including enhancement of positive heritage impacts for community beneficiation;
- All efforts leading to either in-situ or ex-situ conservation of identified heritage features must be undertaken by the PIU especially those identified within the project area;
- The approach to documentation, conservation planning and implementation must be undertaken in consultation with the Department of Culture in the Ministry of Tourism, Environment and Culture. This approach does not only deal with negative impacts, but is required also in the case where improvements are required to present identified heritage feature for public consumption;
- Should the PIU intend to support heritage conservation outside the project area through the social responsibility obligations, it shall do so with the involvement of the National Heritage Authority;
- Awareness in the form of leaflets, meetings and workshops, shall be made to the workforce and the neighbouring community on a regular basis.

INDUCTION/TRAINING

All personnel, especially those working on excavations, are to be inducted on the identification of potential heritage items/sites and the relevant actions for them with regards to this procedure during the project induction and regular toolbox talks

HERITAGE DATABASE

Establish a Heritage Database within the actual and perceived sphere of influence.

- Determine the origin of each artefact or feature identified;
- Continuously survey site to identify heritage sites (building remains, artefacts grinding stones, anvils etc.) and graves;
- The workers must inform the LREEAP ESS and or the CLO for any earth works to be carried out so that the area can be surveyed for identification of heritage sites. In the event where the heritage features are discovered during excavations, the activity shall

be suspended and the ESS shall be informed in order to they can carry-out an investigation;

- Record details in incident report and take photos of the find;
- A rapid assessment of the site or heritage resource to determine its importance should be carried out;
- Decisions on how to handle the finding shall be taken by the responsible authorities;
- Construction works could resume only after permission is granted from the responsible authorities.

MANAGEMENT MEASURES AND RESPONSE

The following action are essential for the preservation and protection of cultural resources on site:

- Known heritage sites and graves must be fenced and marked to maintain or enhance protection from damage until technical evaluation has been sought;
- If there is an accidentally excavated heritage item (grave or artefact) during earth works reasonable measures will be implemented to prevent damage to the grave or artefact;
- Work must be stopped immediately and valuation of the element significance and the next course of action identified in consultation with the ESS and CLO and responsible Authority;
- Artefact must be examined by a suitably qualified specialist. This can be outsourced in liaison with the Heritage Authority, primarily at the district level to facilitate suitability;
- Post assessment, the specialist must provide a go ahead for work to resume after appropriate action of onsite conservation or removal to a more secure place has been concluded;
- Documentation is followed by an assessment of conservation status for inclusion in a management protocol (i.e. to preserve it in-situ or ex-situ; and the steps to be followed to present it to the public).

11.7 PUBLIC PARTICIPATION & CONSULTATIONS REPORT

APPROACH

An open and transparent consultative approach was employed to steer the preparation of an Environmental and Social Management Plan (ESMP) for the Ha Nkai Solar Mini-grid under Lesotho Renewable Energy and Energy Access Project. The qualitative data collection tools used was a semi-structured interview with Area Chiefs, Key Informant's Interviews (KIIs) and institutional consultations. Data was collected on the institutions within villages: Chiefs: small-scale businesses - shops, health facilities, churches, and police where available—semi-structured questionnaire guided interviews.

11.7.1 KEY INFORMANT INTERVIEWS (KII)

Guiding questions for KII included the following:

- Awareness of the Project;
- Anticipated participation of the organisation in the project;
- Anticipated benefits from the project by the organisation;
- How the country and beneficiary communities will benefit from the project;
- Previous challenges from similar projects;
- Foreseen challenges for the proposed project;
- Measures that can be implemented for the protection of the environment and communities during the project implementation
- General comments - questions, concerns and recommendations

Information obtained from the key Informants is presented in Table 11- 1 and one of the key issues mentioned by private sector representation is initial low electricity uptake by rural communities which affects the sustainability or profitability of mini-grid.

Table 11- 1: Key informant interviews

Name of organisation	Description of Organisation	Comments
MOSCET Mr. Khotso Mosito (Owner)27/02/24	Mos-Sun Clean Energy Technologies (PTY) Ltd, trading as MOSCET, is one of the Lesotho based leading renewable energy technology companies. It is	The company is aware of the project as it was invited to project meetings in the past and anticipates that it will provide services as Contractors and designer since this is the company's speciality. Some of the anticipated benefits anticipated to private sector in this line of business are:

Name of organisation	Description of Organisation	Comments
	<p>committed to revolutionizing the energy landscape and making a positive impact on communities across the Kingdom of Lesotho. Its fundamental goal is to offer clean, efficient, and reliable energy solutions that empower thousands of households, communities, institutions, small and large businesses. It has implemented a number of renewable energy projects in Lesotho from 2010 to date ranging from installation of solar geysers to solar street lighting and solar mini-grids and solar PV systems installations.</p>	<ul style="list-style-type: none"> - Profits/income as a private sector; - Expanding of footing in service provision in this sector; <p>The communities will benefit by having access for clean energy and there will be improvements in service provision in schools, health centres as well as establishment of new commercial activities that are dependent on energy access. It would also be good to aim circular economy such as models implemented for the two community-based mini-grids (Motete and Linakeng).</p> <p>Concerns mentioned include:</p> <ul style="list-style-type: none"> - Institutional issues between government e.g. regulatory bodies and private sectors and communities; - Accessibility in rural areas is difficult hence costly construction; - Low usage of electricity by rural communities. <p>The following challenges were experienced in the past:</p> <ul style="list-style-type: none"> - Accessibility difficulties during the construction and operation phase of the project; - Level of acceptance by the communities is low at the beginning but increases with time hence the rate of recovering costs is slow. <p>It is therefore recommended that:</p> <ul style="list-style-type: none"> - There must be ownership by the communities to prevent vandalism. Engage them at every stage; - Mini-grid plants have to be within the villages to prevent theft; - Communities have to be educated on the importance of electricity in income generation; - There needs to be serious engagement between private sector and government in terms of implementation of this project and its profitability to private sector. <p>General comments:</p> <p><i>Questions:</i></p> <ul style="list-style-type: none"> - How can we be assured that our financial

Name of organisation	Description of Organisation	Comments
		<p>contribution as the private sector will be recovered?</p> <p><i>Concerns:</i></p> <ul style="list-style-type: none"> - Recovery of costs for private sector is a great concern for this project; - Tendering will be open international companies as well who may offer lower tariffs but not fully understanding the terrain challenges thereby making competition to be unfair; - National electricity tariffs are significantly cheaper for end-users compared to those of solar mini-grids hence the likelihood of low uptake by communities; - There may be challenges in cases where national grid is brought closer for the mini-grid due political influences. Mini-grids have to be at least 15 km from the national grid; - Private sector views were not considered in developing the project concept yet they have experience with challenges related to this project; - Terrain in Lesotho rural areas is very challenging; - Willingness and ability to pay in the rural areas is low therefore making it risky for the private sector. <p><i>Recommendations:</i></p> <ul style="list-style-type: none"> - There has to be awareness on productive uses of electricity in the project areas so as to ensure usage of electricity. This implies that there will have programs aimed to training communities on how to start and run business that require reliable energy such as workshops.
<p>Department of Energy Ms. Itumeleng Ramone Ms. Nthabeleng Tlali Ms. Qenewe</p>	<p>The Department of Energy was created in 1985 as a department within the then Water, Energy and Mining Ministry (WEMMIN). Its vision is to ensure universally accessible and</p>	<p>DoE developed the project from conception and forming the PIU and is involved in monitoring the project together with the Ministry of Development and Ministry of Finance. The project is aimed towards implementation of Lesotho Energy Policy 2015-2025. Extending the national grid to these areas would be more expensive hence this project will benefit the communities by providing energy access.</p>

Name of organisation	Description of Organisation	Comments
<p>Maqekoane 29/02/2024</p>	<p>affordable energy in a manner that is not only sustainable but with minimal negative impact on the environment.</p>	<p>Challenges experienced from similar projects include:</p> <ul style="list-style-type: none"> - Communities not having the capacity to run the community based mini-grids; - Concession agreements for Sustainable Energy for all (SE4all) project took a long time because it was a new concept. Lessons learnt will make things easier for similar projects going forward; - The Contractor would require 80% of the community to pay for connection fee in order to commence with connections and this was challenging; - Other communities complained that their areas were omitted hence the scope had to be increased therefore increasing project costs; - Difficult terrain and scattered villages leading to more costs for project implementation; - Generation of e-waste of previous solar projects in which panels and batteries were provided at household/individual level; - It is difficult to find funders/ donors/ investors for Renewable Energy since there is no subsidy policy as yet in the country. The plan is to develop it under the same project (LREEAP). The subsidy should also be done in such a way that it benefits the end users; - Mini-grid usage tariffs are expensive for rural communities especially because some know how much LEC electricity currently costs; - Contractors have to consider issues of terrain at project sites in order to develop informed tender documents. <p>General comments</p> <ul style="list-style-type: none"> - It would also be good for local companies to partner with international companies with more financial capacity and expertise so that there may be skills transfer. The project is still at an early stage hence the PPP model for this project is still has to be clearly defined; - There has to be coordination between line

Name of organisation	Description of Organisation	Comments
		<p>ministers for other infrastructure such as roads and water supply to ease project implementation in various places;</p> <ul style="list-style-type: none"> - Identification of areas of environmental significance or heritage sites or private or communal properties is key in the design; - The communities will have to be convinced that the equipment for mini-grids is expensive for isolated plants therefore the tariff will not be the same as that of the national grid; - Communities will also have to get clarification that infrastructure for national grid will be more expensive for them due to distances.
<p>One Power Lesotho Ms. Kekeletso Rakoti and Mr. Jan Schalk (EHS Lead and Director of operations) 29/02/24</p>	<p>1PWR is a fast-growing start-up based in Lesotho whose mission is to provide affordable and reliable electricity services to off-grid villages and underserved communities. The Lesotho based start-up is passionate about high quality engineering and service provision and working with and in the communities it serves. The company portfolio includes grid connections, innovations in which novel software and hardware solutions for the renewable energy sector have been created as well as off-grid options for powering rural communities in hard-to-reach areas.</p>	<p>The company does intend to participate in the project. As much as the communities will benefit from energy access, It is important to note that the company may experience benefits from the project after a prolonged period of time when usage by end-users has increased. The following challenges were highlighted:</p> <ul style="list-style-type: none"> • Mini-grids are practically only feasible with subsidy due to high capital expenditure; • Accessibility of most rural areas in Lesotho is very difficult thereby causing delays during construction; • Accessibility also affects attendance of public gatherings hence low participation of other community members in such projects due to limited knowledge about productive uses of electricity; • Low temperatures and strong winds also lower productivity; • In some cases, there will be a need to make temporary access roads or use people and animals for transportation; • Ability to pay for connection fee and usage is a challenge in rural areas due to socio-economic conditions; • There were incidents of lightning strikes in other

Name of organisation	Description of Organisation	Comments
		<p>similar projects since earthing was not adequately done due to limited/delayed financing.</p> <p>The following recommendations were made:</p> <ul style="list-style-type: none"> • Sensitisation of communities to ensure ownership; • Engagement of labourers from villages to avoid conflicts. <p>General Comments:</p> <p><i>Questions</i></p> <ul style="list-style-type: none"> - Is the ESMF for the project already prepared? - Will Contractors be expected to develop site specific ESMPs in order to obtain environmental clearance from the Department of Environment? <p><i>Concerns</i></p> <ul style="list-style-type: none"> - The Department of Energy might not be very interested in the project when there is no more external funding; <p>There are some unknowns (such as damaged access roads) in the project which may affect timelines</p>
<p>NUL ERC Prof Lebuli Thamae (Coordinator) 04/03/24</p>	<p>This a research centre within NUL which is set to respond to Lesotho’s energy and climate change challenges through the development and/or adaptation of knowledge and technologies that usher a smooth transition to a sustainable energy system. NUL ERC seeks to be a leading national hub in energy efficiency and renewable energy studies, related knowledge and information management, and development-oriented activities.</p>	<p>NUL Energy Research Centre (ERC) anticipates research in the project through among others sharing experiences from similar mini-grids which they have developed. ERC also wishes they could receive support financially from LREEAP as some their ongoing projects need additional financing due to the impact of COVID-19 on the timing of their project.</p> <p>The communities will benefit from the proposed project but there has to be substantial subsidy in order to reduce the tariff for end users most people in the rural areas have low ability to pay. The communities will also have to be made aware of productive uses of electricity.</p> <p>Some of the challenges experienced in similar projects include:</p> <ul style="list-style-type: none"> - Poor workmanship in distribution lines, some are low; - Organising communities for meaningful participation was difficult;

Name of organisation	Description of Organisation	Comments
		<ul style="list-style-type: none"> - Bodies running mini-grids have to be corporate entities so we ended up forming corporates which has challenges. Forms in English therefore commencing couldn't go on; <p>Potential challenges for the proposed project may include:</p> <ul style="list-style-type: none"> - Challenges with e-waste disposal for end-of-life batteries (have to be replaced after 5 to 7 years) or solar panels (have to be replaced after 25 years); - Lack of sustainability if tariffs are not heavily subsidized. <p>General comments</p> <p><i>Questions</i></p> <ul style="list-style-type: none"> - Which model is going to be used for implementing the project? <p><i>Concerns</i></p> <ul style="list-style-type: none"> - Lack of follow-up or implementation by the government e.g. there were masterplans developed before but they were not followed up; - It is going to be costly to build distribution networks due to nature of villages (highly dispersed and small); - ERC is considered as a stakeholder in the proposed project but its role has not been clarified; - There is normally low uptake by the communities during the first few years leading to cash flow as such problems may occur leading to maintenance issues being a challenge. <p><i>Recommendations</i></p> <ul style="list-style-type: none"> - Electrification strategy has to be updated and should include mini-grids; - Service value test has to be conducted; - Conduction of baseline assessment and then an impact assessment after a few years of implementation.
Lesotho Electricity Company	LEC is entirely owned by the GoL and has been registered	Anticipated challenges or impacts for the proposed project include generation of e-waste when batteries or panels are

Name of organisation	Description of Organisation	Comments
Ms Mot’selisi Moremoholo - Risk Manager	in terms of the Companies Act of 1967 (as amended) and established in 2006 in terms of the LEC (Pty) Ltd Establishing and Vesting Act 2006. Its mission is to provide reliable, safe, environmentally friendly and quality electricity for sustainable economic growth and improved quality of life for the people of Lesotho.	due for replacement. In addition, the project areas are rural and remote areas where there may be rare and/or endangered bird species. Birds are likely to be impacted by reflection from the solar panels or collisions by distribution lines. A significant environmental impact which was experienced at Ramarothole solar plant is severe soil erosion. Therefore, vulnerability of land to soil erosion at plant sites has to be determined. There may also be grievances in relation to compensation in cases where private property is impacted. Another social challenge is vandalism whereby herd boys throw stones at solar panels.

11.7.2 INSTITUTIONAL CONSULTATIONS AND INTERVIEWS WITH AREA CHIEFS

In order to ensure that all institutions (schools, health centers, stores, churches and more) are aware of the project, the consultant conducted institutional consultations. Institutional consultations provide an opportunity for the consultant to engage with key stakeholders, such as senior management and representatives from different institutions, to gather their input and perspectives regarding the project. This ensures that all constitutions are taken into account and helps to foster collaboration and transparency with the institutions. It also provides an opportunity to address any concerns or conflicts that may arise, leading to a smoother implementation of the project. Guiding questions for institutions and chiefs consultations included the following:

- Current sources of Energy;
- Challenges they encounter with no access to energy supply;
- Environmental and social challenges foreseen during and after the implementation of other projects, both positive and negative impacts;
- Interviewees' suggestions on mitigation strategies for identified challenges;
- Confirmation of leadership of the village's jurisdictional and administrative boundaries;
- Community livelihoods (sources of income and agriculture) and infrastructure services.

A list of the institutions that were consulted in Ha Nkai is provided below (see Table 11- 2):

Table 11- 2: The institutions and respondents consulted in Ha Nkai in the development of this report

Minigrid location	Name of institution	Type/focus of institution	Name of respondent
Ha Nkai	Nkai Health Centre	Health Services	Rhenias Gapare
	Hloahloeng Primary School	Education	Mamorabe Touto
	Hareeng High School	Education	Sechabo Maoeng

DETAILS OF CHIEFS INTERVIEWS

Area chiefs were consulted as part of the site visits conducted for this ESMP. They play a crucial role in mini-grid site visits by providing local knowledge and expertise. They are familiar with the specific energy needs and challenges in their area, and they can provide information on infrastructure, community dynamics, and potential barriers to implementation. Their input helps guide the decision-making and planning process for mini-grid development and ensures the solutions are tailored to the needs of the community.

Date: 13/02/2024

Hloahloeng, Ha Nkai - Maletšabisa Lerotholi

Seforong – Chief Sempe Nkuebe

Ha Seqhoke - Khobotle Khobotle

11.7.3 COMMUNITY AWARENESS (CONDUCTED BY LREEAP) REPORT FOR HA NKAU (2023)

Community awareness was held as shown below:

Ha Nkai (30th November 2022) at 10:30am

Present stakeholders at the public gathering included the following:

- i) Local Chief
- ii) World Bank, LREEAP & DoE PIU
- iii) Community at large

Opening session

Welcome remarks were made by the chief of Ha-Nkai Chief Letlama. He proceeded by requesting the team from LREEAP-DoE to take the platform and continue with the day’s agenda.

LREEAP Coordinator Ms Mathapelo gave a brief but detailed outline of the purpose of the visit. She explained that the main goal of the government of Lesotho through LREEAP is to make electricity accessible to all Basotho. She said the team visited Ha-Nkau because its villages have been identified through a feasibility study that was conducted as one of the beneficiaries.

Presentations and Discussions

Mr Kokome, introduced the Project to the community leaders and proceeded by giving a brief explanation on what a mini-grid is and how it works. He also highlighted that the users will not feel any difference between the mini-grid electricity and the one they usually get from LEC. The E&S Specialist, Mr. Lepekola, highlighted to the community leaders about the importance of E&S issues and touched on the key ones that the community needs to take note of:

Issues of concern and comments from the community members regarding what had been communicated to them were discussed. The issues raised by the communities are contained in a table below.

Comments and questions of the participants

QUESTIONS /VIEWS/COMMENTS
1. Is there a time we will need to pay for the installation?
2. What if the owner of the field is the one who shows where to place the pole?
3. Electricity poles should not be installed in graveyards
4. Our problem is water, wood and electricity
5. We are thankful and promise to work together with you

The Community was further given a chance to say how they believe electricity will help them. Their responses are contained in a table below.

Responses to Comments and questions of the participants

RESPONSES
• At schools, there will be computers
• We need to be kept updated through TV's
• We will need fridges to keep chickens to sell
• Our businesses need electricity so that food don't get spoiled and we need it for security
• Electricity will be our security, we will even have alarms when there is electricity

RESPONSES

- I do not know anything about electricity or its use except that we use it to generate water.
- Electricity will help health-wise, people will not eat rotten food so they will not be sick.
- If we can have water, roads and electricity, then we will be lacking nothing to have help us live.
- Our clinic needs electricity so that machines will work.

Closing remarks

Ms Palesa from DOE asked if there is a community scheme and a committee. The response was No, there isn't any. Ms Mathapelo then recommended that they should start one so that the project becomes a success. Questions rose as to what they need to do to start one and how they should go about it. Ms Mathapelo promised to send her colleagues who work with the community on schemes to come and guide them, but she advised that each village should have a group of people who will form a committee.

All people present were then given T-shirts and caps and a group photo was taken.

NAMES OF HA-NKAU VILLAGES PRESENT

Ha Kojoana, Ha Nkau, Pitsaneng, Molatsi, Seberetlane, Matliseng, Ha Seqoke, Ha Phafoli, Ha Mphutlela, Ntoa-hae, Ha Tumo, Ha Thuhloane, and Lilibaneng.